

# RTAXQ1-190 RTAXQ1-190D RTAXQ1-190-2

## Owner's Manual

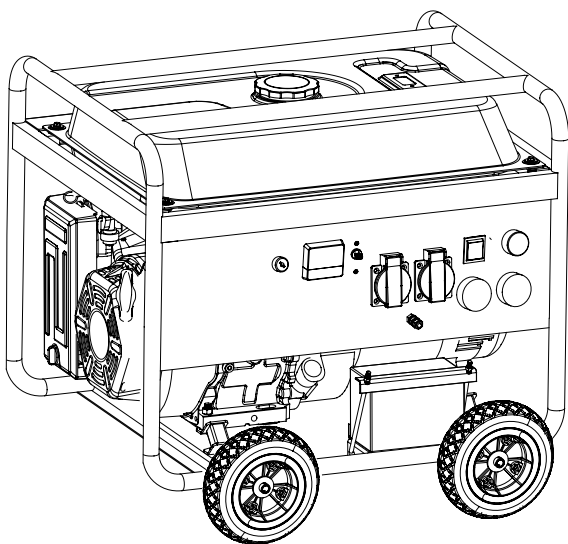



## **PREFACE**

Thank you for purchasing our welder.

This manual contains the information on how to do that. Be sure to read it carefully before operation. Operate it safely and correctly, you can get the best results.

All information and diagrams in this publication is based on the latest products information available at the publishing time. The contents in this manual may be different from the actual parts due to revision and other changes. Our company reserves the right to make changes at any time without notice and without incurring any obligation. No part of this publication may be reproduced without our Company's written permission.

This manual should be considered a permanent part of the welder and should remain with the welder if resold.

## **SAFETY MESSAGES**

Your safety and the safety of others are very important. We have provided important safety messages in this manual and on the welder. Please read these messages carefully.

A safety message alerts you to potential hazards that could hurt you or others. Each safety message is preceded by a safety alert symbol  and one of three words: DANGER, WARNING, or CAUTION. These mean:

 **DANGER** You **WILL** be **KILLED** or **SERIOUSLY HURT** if you **don't follow instructions.**

 **WARNING** You **CAN** be **HURT** if you **don't follow instructions.**

 **CAUTION** Your gasoline engine or other property could be damaged if you **don't follow instructions.**

**NOTICE** Your welder or other property could be damaged if you **don't follow instructions.**

---

## CONTENTS

PREFACE .....	1
SAFETY MESSAGES .....	2
CONTENTS .....	3
I. SAFETY MESSAGE .....	4
II. COMPONENT IDENTIFICATION .....	5
III. CONTROL.....	8
IV. WELDER OPERATION .....	12
V. CHECK BEFORE OPERATION .....	14
VI. STARTING THE WELDER.....	17
VII. STOPPING THE WELDER .....	19
VIII. MAINTENANCE .....	20
IX. STORAGE .....	25
X. TROUBLESHOOTING.....	27
XI. WIRING DIAGRAM .....	32
XII. SPECIFICATIONS .....	35
XIII. WHEEL (OPTION) .....	36

## **I. SAFETY MESSAGE**

Read and understand this owner's manual and acquaint the welder's safe operating procedures before operating your welder. That can help you avoid accidents.

1. Keep the welder far away from the inflammable and explosive material in operating.
2. Don't operate the welder in the closed area or in the poor ventilated places in order to avoid carbon monoxide poisoning!
3. Do not touch the high voltage power supply in using it.
4. The muffler and engine are very hot during running the welder. Never touch them, or you may get burns.
5. Stop the engine and keep the fire source far away when refueling.
6. Don't cover the welder with objects and left around at least 1 meter distance in order to facilitate the cooling unit.
7. Pay attention to the safety while operate welder in the rainy and snowy days. Do not touch motor and distribution lines with wet hands in order to avoid an electric shock accident.
8. Cooling air temperature does not exceed 45 °C.
9. Air relative humidity is not more than 80%;
10. Use welder in the absence of conductive dust and corrosive gases.
11. The environmental temperature change will affect the action of circuit breaker. Please replace the circuit breaker which is suitable to the local temperature.

## II. COMPONENT IDENTIFICATION

### 1. Feature

#### RTAXQ1-190/RTAXQ1-190D

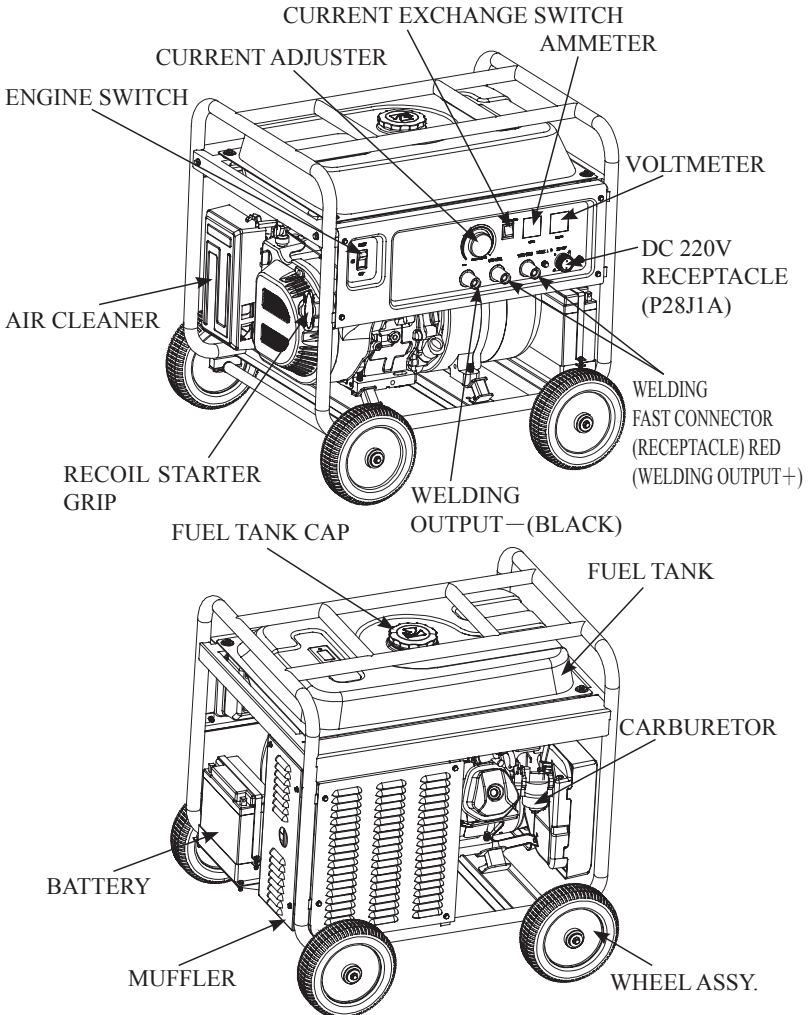

# RTAXQ1-190-2

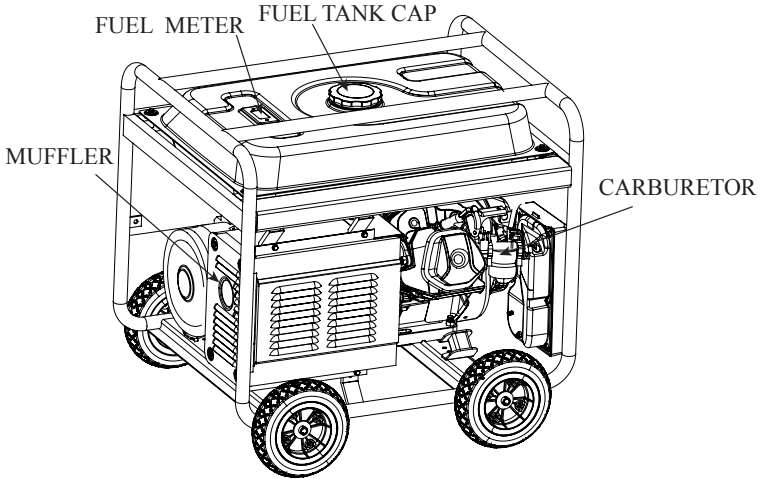
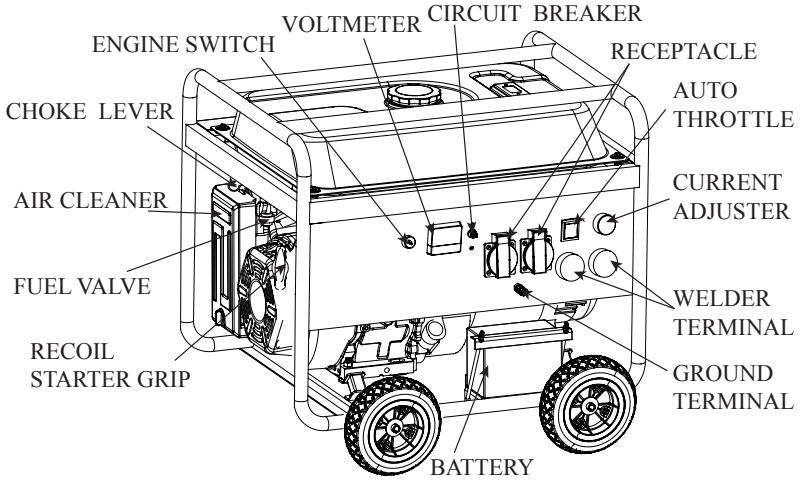



## 2. Model No.

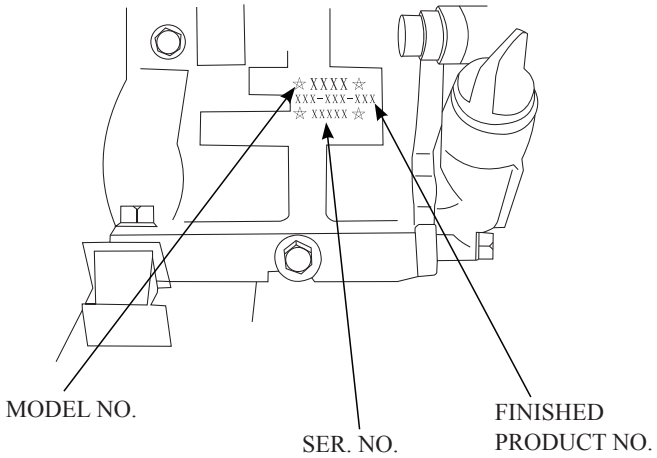

### III. CONTROL

#### 1. Engine Switch

Engine switch: press the button up to " START" position. the engine will start .After starting engine, immediatelly release engine switch and engine switch can automatically return to "ON" position; press the button down to "OFF" position, the engine will stop running.

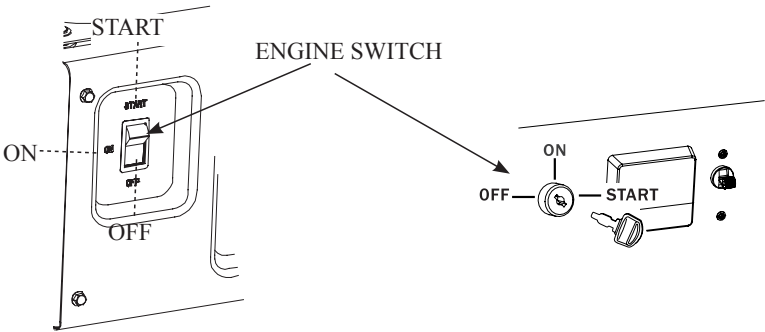

#### 2. Recoil Starter

Starter grip: To start the engine, pull the starter grip lightly until resistance is felt, then pull out abruptly, repeat to start the engine.

**NOTICE** Do not allow the starter to snap back. Return it gently.

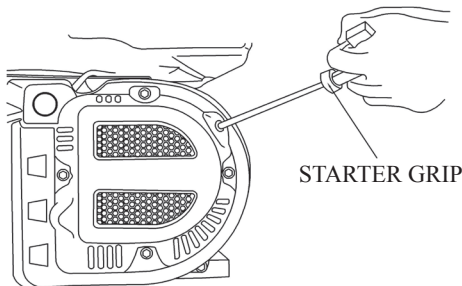

### 3. Fuel Valve

Fuel valve: fuel flows from the fuel tank to carburetor when the fuel valve is in "ON" position and in " OFF" position will cut off fuel flowing to carburetor.

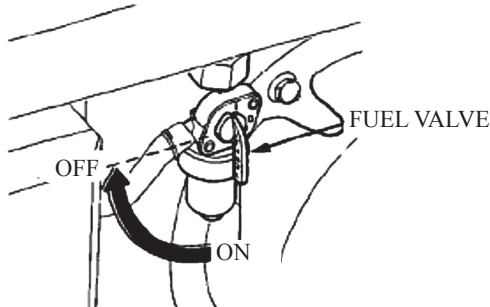

### 4. Choke Lever

Chock lever: in "CLOSE" position, carburetor provides an enriched fuel mixture; in "OPEN" position, carburetor provides a natural working mixture.

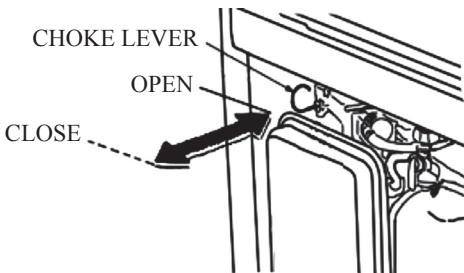

### 5. Circuit Breaker

Troubled load or incorrect connection will result in circuit overload. At this time the circuit breaker knob projects in "OFF" position, which will automatically cut off standby power to protect. After malfunction exclusive, press the circuit breaker knob to "ON" position.

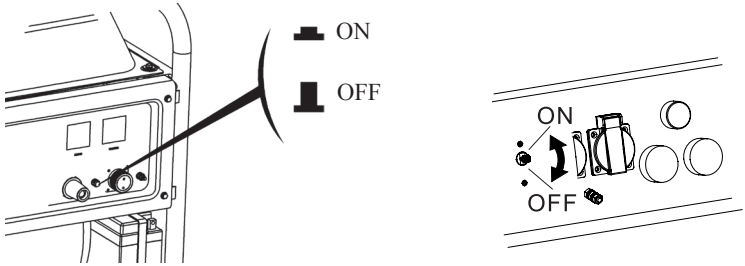

### 6. Ground Terminal

This ground terminal is specially used to connect the welder to the ground.

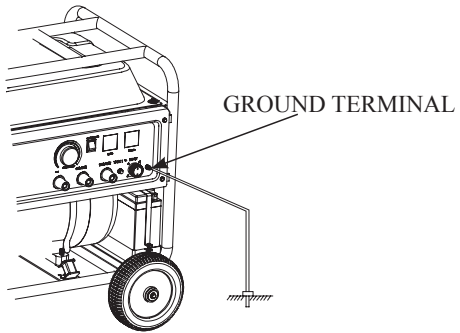

### 7. Current Adjuster

Adjust the current according to welding requirement.

#### CURRENT ADJUSTER



## 8. Auto Throttle

The solenoid valve will operate and engine keep idle speed when the switch turn ON and electric welder set is no load. For engine operating, switch ON the load and solenoid valve disconnect.

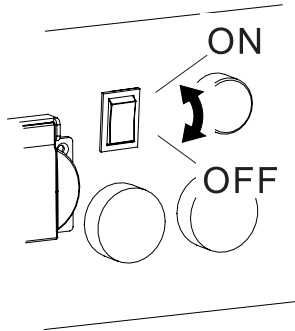

## 9. Oil Alert System

The oil alert system is especially designed to prevent welder from damaging caused by an insufficient amount of oil in the crankcase. When the oil level in the crankcase fall down below a safe limit, the oil alert system will automatically shut down the welder (though the welder switch still remains in “ON” position), so that the welder can’t be damaged resulting from the insufficient amount of the oil.

## **IV. WELDER OPERATION**

### **1. Welder Operation Environment:**

- 1) Height above sea level: Do not exceed 1000 ml.
- 2) Operation environment temperature.  
welding: -10~+40°C;  
transportation and storage: -25~+55°C.
- 3) Air relative humidity: Don't exceed 50% at 40°C; and don't exceed 90% at 20°C.
- 4) The air dist, acid, corrosive gases around place will be less than normal content, except these substances from welding process.
- 5) Place it at dry and ventilated area, and avoid to expose in the sunshine and rain.
- 6) Place this serial products at area which the gradient is less than 15°C,  
When placing the welder at tilted plane, be careful not turnover.

### **Welder placing requirement:**

If a carburetor suited a high altitude is equipped with engine suited a lower altitude, the lean air fuel mixture will make engine output power decline, over-heat and seriously damage.

### **2. Welder Grounding**

To prevent electrical shock from the poor quality electrical appliance or misuse, we suggest that connect the welder to ground with insulated leathern fine quality leads.

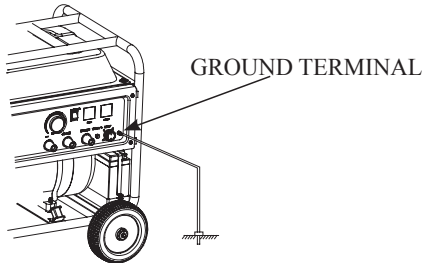

### 3. Auxiliary Power Supply

1.This series welder is with auxiliary DC output. The voltage is 220V, which can be used for the electrical tools below 3KW with carbon brush.

DC RECEPTACLE

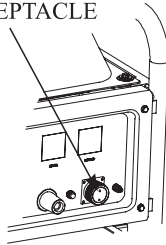

2.This series welder is with auxiliary AC output. The voltage is 230V, which can be used for the electrical tools below 3.5KW with carbon brush.

AC RECEPTACLE

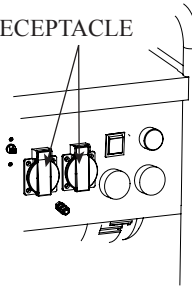

#### NOTICE

- Don't connect to household electrical appliance directly.
- Don't use the auxiliary power supply at one time when welding.

## V. CHECK BEFORE OPERATION

### 1. Engine Oil

#### NOTICE

Before operation, please stop the welder and put on the flat surface to check the oil level.

Engine oil is a major factor affecting engine performance and service life.

Non-detergent and 2-stroke engine oils will damage the engine and are not recommended.

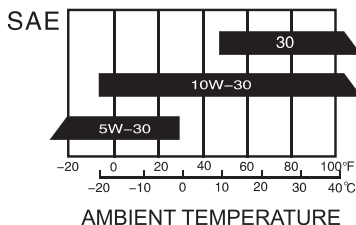

Recommended oil

4-stroke gasoline oil

API service Classification's SF or SAE10W-30 of equivalent SG class.

Method of check oil level:

Remove the oil filler cap and wipe the dipstick clean.

Check the oil level by inserting the dipstick into the filler neck without screwing it in.

If the level is too low, add the recommended oil to the upper mark on the dipstick.

After adding, don't forget reinstall and tighten the oil dipstick.

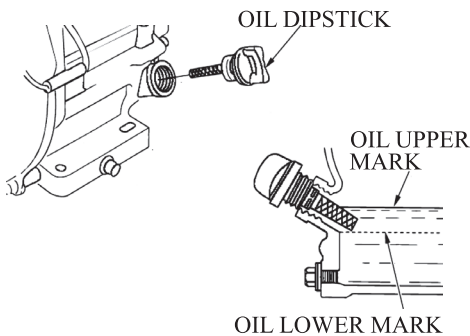



## 2. Fuel

- 1) Check the fuel level gauge,
- 2) Refill the tank if the fuel level is too low. Do not fill above the shoulder of the fuel strainer.
- 3) Reinstall and tighten the fuel tank cap after refueling.

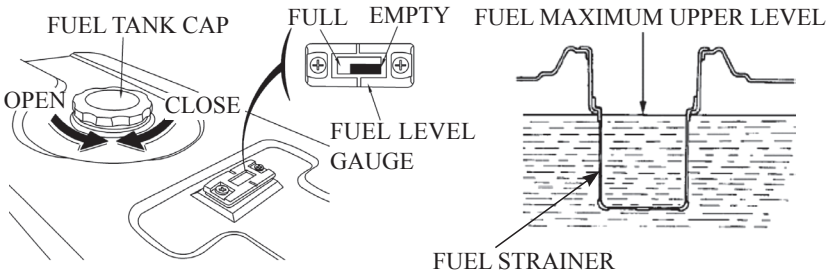

### **⚠ WARNING**

- **Refuel in a well-ventilated area with the engine stopped. Do not smoke or allow flames or sparks in the area where the engine is refueled.**
- **Do not overflow the fuel from the fuel tank.**
- **Avoid repeated or prolonged contact the fuel with skin or breathing of vapor.**
- **Keep out of reach of children.**
- **Don't use the oil and gasoline mixture or gasoline with impurity.**

Use gasoline with octane rating  $\geq 90$  higher.

We recommend unleaded gasoline because it produces fewer deposits of engine and spark plug and extends exhaust system life.

Never use stale or contaminated gasoline or oil/gasoline mixture. Avoid dirt or water entering into the fuel tank.

### 3. Battery

Please use battery with voltage 12V.

#### NOTICE

**Don't connect the battery positive and negative poles in reverse (Pay attention to leads mark), when connecting, first connect positive poles, then negative poles, when disassembling, first negative pole, then positive pole, if not, can seriously damage the welder and battery.**

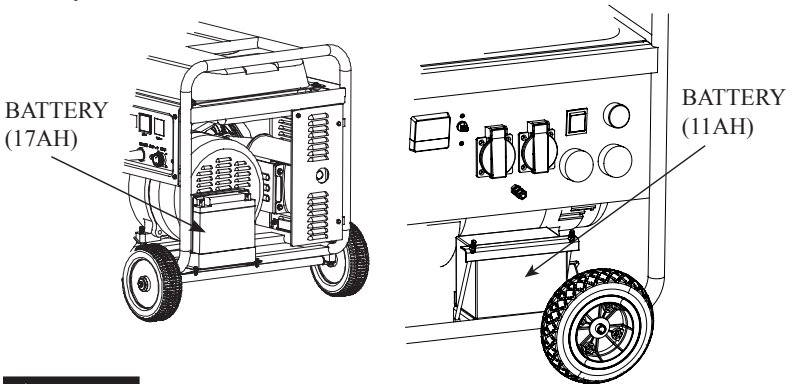

#### ⚠ WARNING

- **If improper operation, the battery may be explosive and potentially hurt others nearby. Keep the fire and inflammable materials far away from the welder.**
- **The battery will release the explosive gas, please keep the fire far away from. Keep the air ventilating when battery is charging and using.**

## VI. STARTING THE WELDER

### 1. Recoil Starter

- 1) Remove all the loads out of the output terminal.
- 2) Turn the fuel valve to “ON” position.
- 3) Turn the choke lever to “CLOSE” position.

#### NOTICE

**Don't close the choke lever when starting the engine in warm state.**

- 4) Turn the engine switch to “ON” position.
- 5) Pull the starter grip until resistance is felt, then pull out rapidly.
- 6) Turn the choke lever to “OPEN” position after the engine is warm.

### 2. Electric Starting

- 1) Remove all the loads out of the output terminal.
- 2) Turn the fuel valve to the “ON” position.
- 3) Turn the choke lever to “CLOSE” position.

#### NOTICE

**Don't close the choke when starting the engine in warm state.**

- 4) Turn the engine switch to electric starting position to start.
- 5) Unclinch the engine switch after starting the engine, the engine switch will turn back to “OPEN” position automatically.
- 6) Turn the choke lever to “OPEN” position after the engine is warm.

#### NOTICE

**Turn the engine switch to electric position for less than 5 seconds or**

**can damage the starting motor. If failing to start, release the switch and wait 10 seconds before operating it again.**

**If the speed of the starting motor drops fast after a period of time, it means that the battery should be recharged.**

## **VII. STOPPING THE WELDER**

1. Turn the AC circuit breaker to “OFF” position.
2. Turn the engine switch to the “OFF” position.
3. Turn the fuel valve to the “OFF” position.

### **NOTICE**

**If need to stop the engine in an emergency, turn the engine switch to “OFF” position.**

## VIII. MAINTENANCE

Good maintenance is essential for safe, economical, and trouble-free operation. It will also help reduce air pollution.



**Exhaust gas contains poisonous carbon monoxide. Shut off the engine before performing any maintenance. If the engine must be run, make sure the area is well ventilated.**

Periodic maintenance and adjustment is necessary to keep the welder in good operating condition. Maintenance schedule as follows:

REGULAR SERVICE PERIOD		Each use	First month or 20 Hrs. (3)	Every 3 months or 50 Hrs. (3)	Every 6 months or 100 Hrs. (3)	Every year or 300 Hrs. (3)
Engine Oil	Check oil level	○				
	Change		○		○	
Air cleaner	Check	○				
	Clean			○(1)		
Sediment Cup	Clean				○	
Battery Voltage	Check		○		○	
Spark Plug	Clean				○	replace
Valve Clearance	Check-Adjust					○(2)
Cylinder Head	Clean	Every 300 hours (2)				
Fuel Tank and Strainer	Clean	Every 2 years (2)				
Fuel Tube	Replace	Every 2 years (2)				
Cylinder head and the head of piston	Clean carbon	Every 250 hours(2)				

- (1) Service more frequently when used in dusty areas.
- (2) These items should be serviced by an authorized dealer.
- (3) When use frequently, service according to above correct intervals can insure the electric welder long-term use.

**⚠ WARNING**

**Improper maintenance or failure to modify a problem before operation can cause a malfunction in which you can be seriously hurt or killed.**

**Always follow the inspection and maintenance recommendations and schedules in this owner's manual.**

## 1. Engine Oil Change

Drain the oil while the engine is warm to assure complete, and rapid draining.

1. Remove the oil dipstick and drain plug to drain the oil.
2. Reinstall the drain plug, then tighten the plug.
3. Refill oil and check the oil level.
4. Reinstall the oil dipstick.

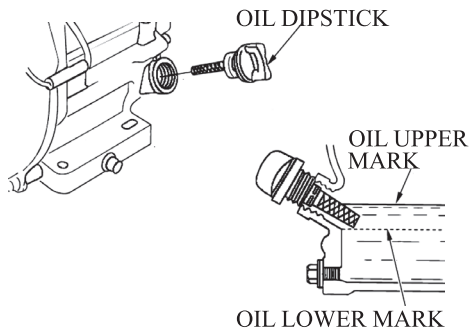

Welder oil capacity: 1.1 L

**⚠ CAUTION**

**Skin cancer may be caused by contacting engine oil frequently for a long time. Although this isn't necessary, it is still advisable to wash your hands thoroughly with soap and water after contacting oil.**

Please dispose of used engine oil in a manner that is compatible with the

environment. We suggest you take it in a sealed container to your local service station or recycling center for reclamation. Do not throw it in the garbage or dump it on the ground and in the raceway.

## 2. Air Cleaner Service

A dirty air cleaner will restrict air flow to the carburetor. To prevent carburetor malfunction, service the air cleaner regularly. Service more frequently when operating the welder in extremely dusty areas.

### WARNING

**Using gasoline or flammable solvent to clean the filter element can cause a fire or explosion. Use only soapy water or nonflammable solvent.**

### NOTICE

**Never run the welder without the air cleaner, or engine will wear rapidly.**

- 1) Remove the air cleaner connection bolt and open the air cover. Check the air cleaner element to insure complete cleanness.
- 2) If the air cleaner element is dirt, please clean the air cleaner element:  
Wash the air cleaner element in warm water with household detergent, or wash in nonflammable or high flash point solvent, then rinse thoroughly and squeeze it. Drop a few points engine oil in, then, squeeze evenly.



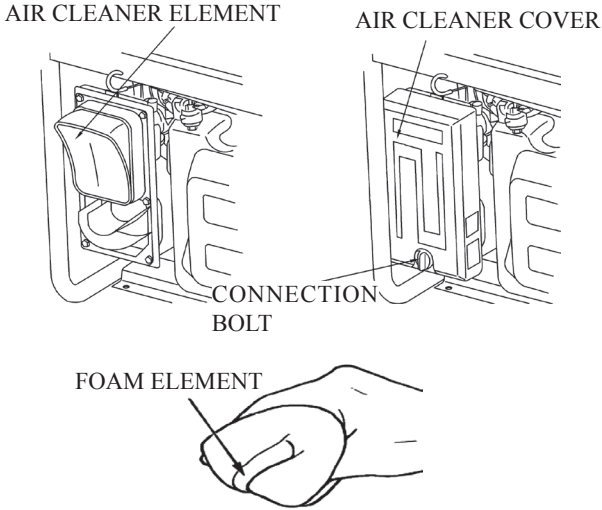

- 3) Reinstall the air cleaner element and the cover.

### 3. Fuel Sediment Cup Cleaning

- 1) Turn the fuel valve to "OFF" position. Remove the sediment cup, o-ring and strainer.
- 2) Clean the sediment cup, and o-ring, and strainer in nonflammable or high flash point solvent.
- 3) Reinstall o-ring, and strainer and screw down the sediment cup.
- 4) Turn the fuel valve "ON" and check for leakage.

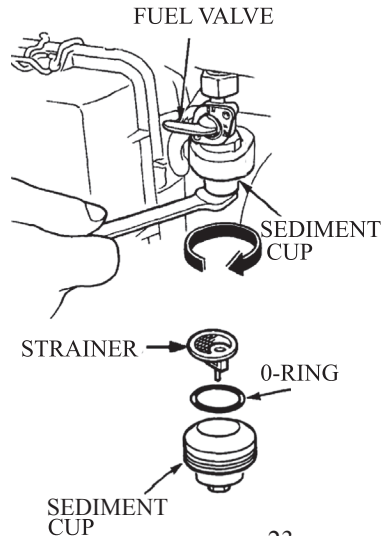

## 4. Spark Plug

Recommended spark plugs: F7RTC.

- 1) Remove the spark plug cap.
- 2) Use the plug wrench to remove the spark plug.

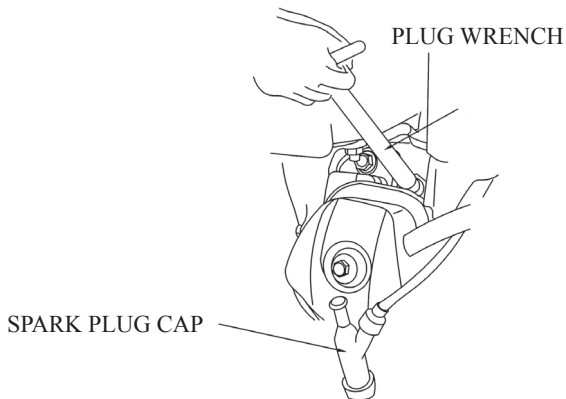

- 3) Inspect the spark plug visually if the insulator is broken, if broken, replace with new the spark plug.
- 4) Measure the plug gap with a feeler gauge. Modify as necessary by carefully bending the side electrode carefully. The gap should be: 0.70-0.80 mm
- 5) Check the spark plug washer is in good condition.
- 6) Install the spark plug on and screw down it with plug wrench, press the plug washer. Cover the spark plug cap on.

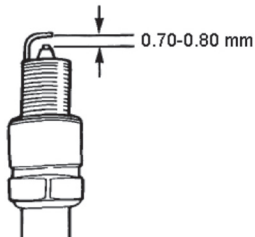

### NOTICE

Please use the spark plug with suitable heat range.

## IX. STORAGE

### **⚠ WARNING**

**In order to avoid inflammation or fires because of contacting with a hot engine or exhaust system, let the engine cool before storing the welder.**

If storing the welder for a long time, make sure the storage area is clean and dry.

1. Drain the fuel from the fuel tank, clean strainer, o-ring and sediment, and then reinstall them well. Drain the fuel out of the carburetor by loosening the drain bolt, and then reinstall it and tighten the carburetor bolt.

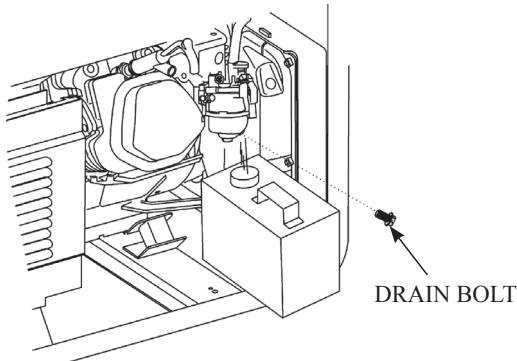

### **⚠ WARNING**

**Gasoline is extremely flammable and explosive under certain conditions. Drain fuel in a well-ventilated area with the engine stopped. Do not smoke or allow flames or sparks in the area during this procedure.**

## STORAGE

---

2. Screw the oil dipstick off and screw the drain bolt off the crankcase to drain the oil out completely. And then tighten the drain bolt and fill fresh oil to upper mark, finally reinstall the oil dipstick well.
3. Remove the spark plug, and pour about a tablespoon of clean engine oil into the cylinder. Crank the engine several revolutions to distribute the oil, then reinstall the spark plug.
4. Slowly pull the starter grip until resistance is felt. Let the intake and exhaust valves in closing position.
5. Place the welder in the clean and dry area.

## X. TROUBLESHOOTING

### 1. Engine Is Unable To Start:

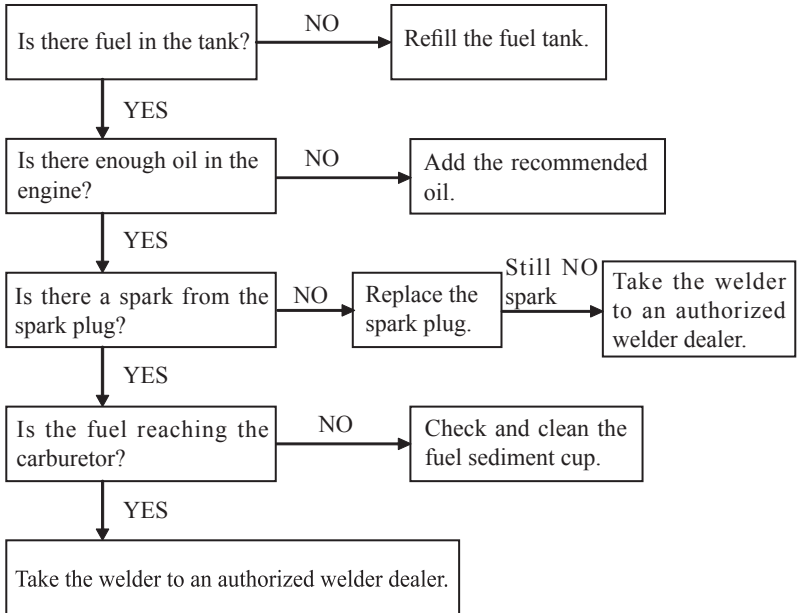

2. Without No Load Voltage Or Unable Generating Electricity  
(RTAXQ1-190/RTAXQ1-190D)

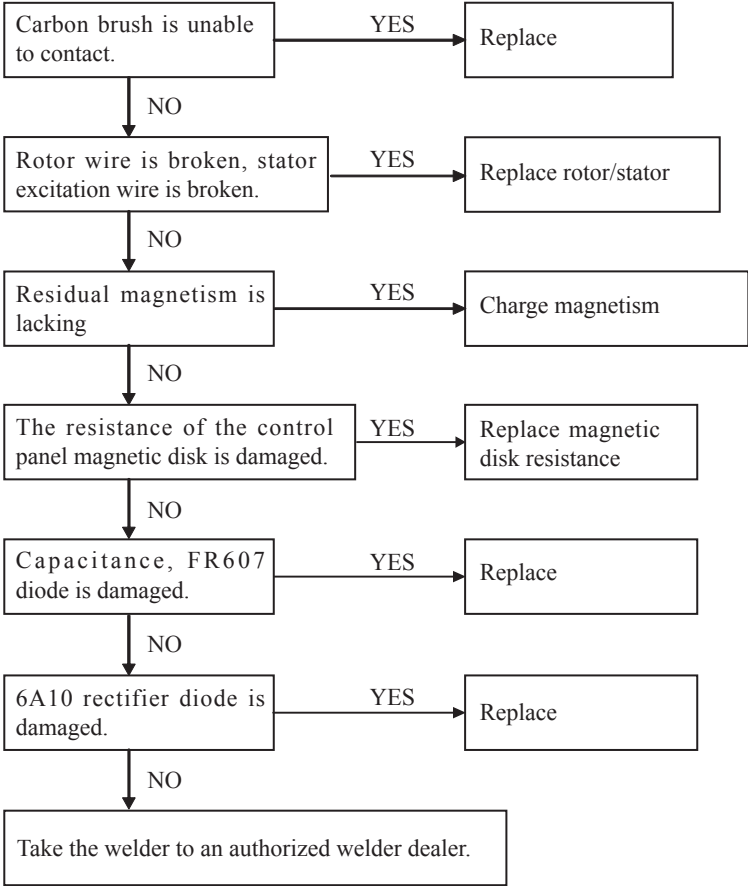

### 3. Without Auxiliary Power Supply.(RTAXQ1-190/RTAXQ1-190D)

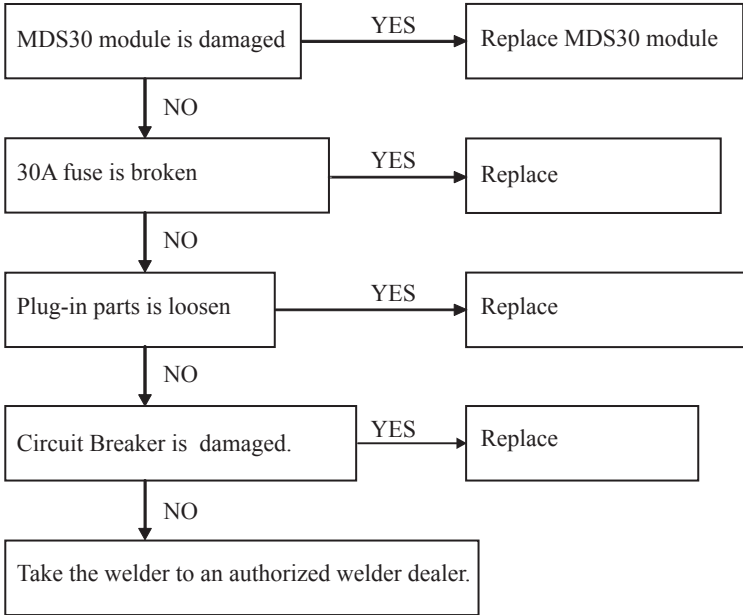

### 4. Maximum Current Lack Or Without Maximum Current Output. (RTAXQ1-190/RTAXQ1-190D)

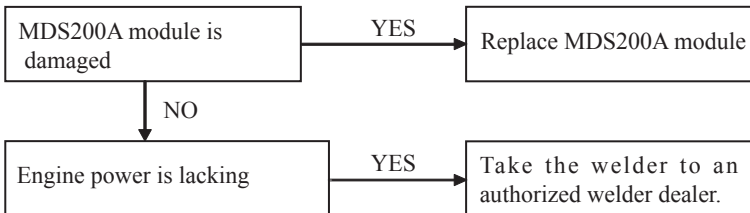

5.No no-load voltage or unable generating electricity (RTAXQ1-190-2)

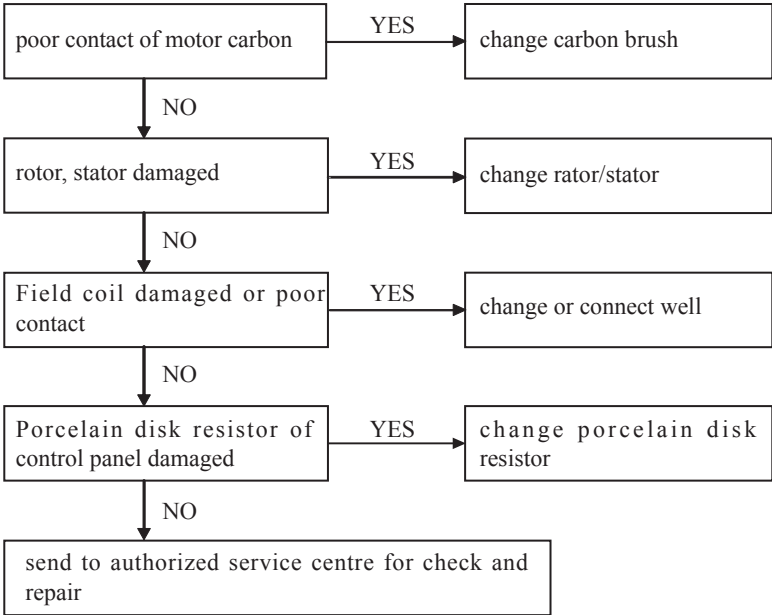

6.No auxiliary power (RTAXQ1-190-2)

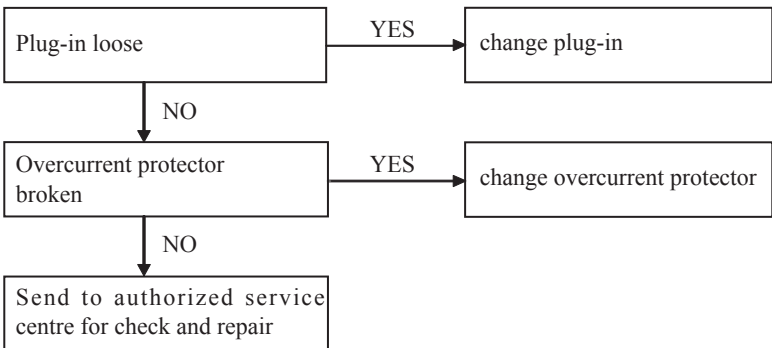



## 7.Low max. current or no max. current output(RTAXQ1-190-2)

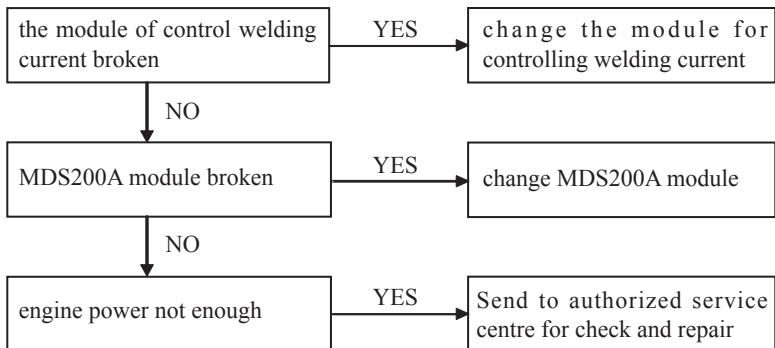

# XI. WIRING DIAGRAM

RTAXQ1-190

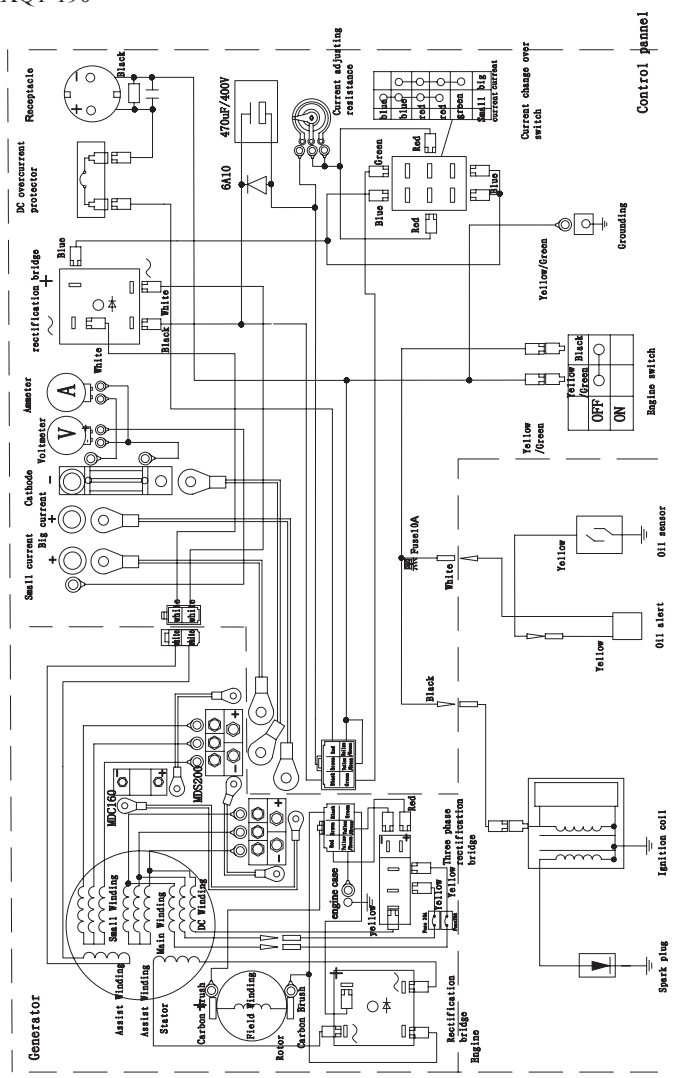

RTAXQ1-190D

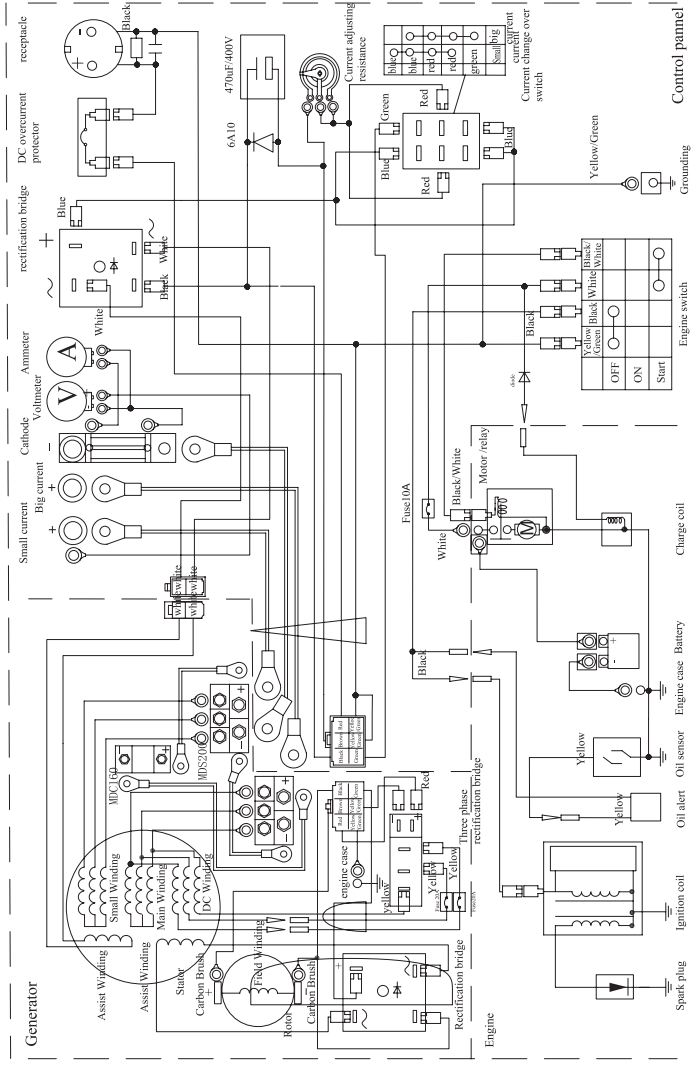

# WIRING DIAGRAM

## RTAXQ1-190-2

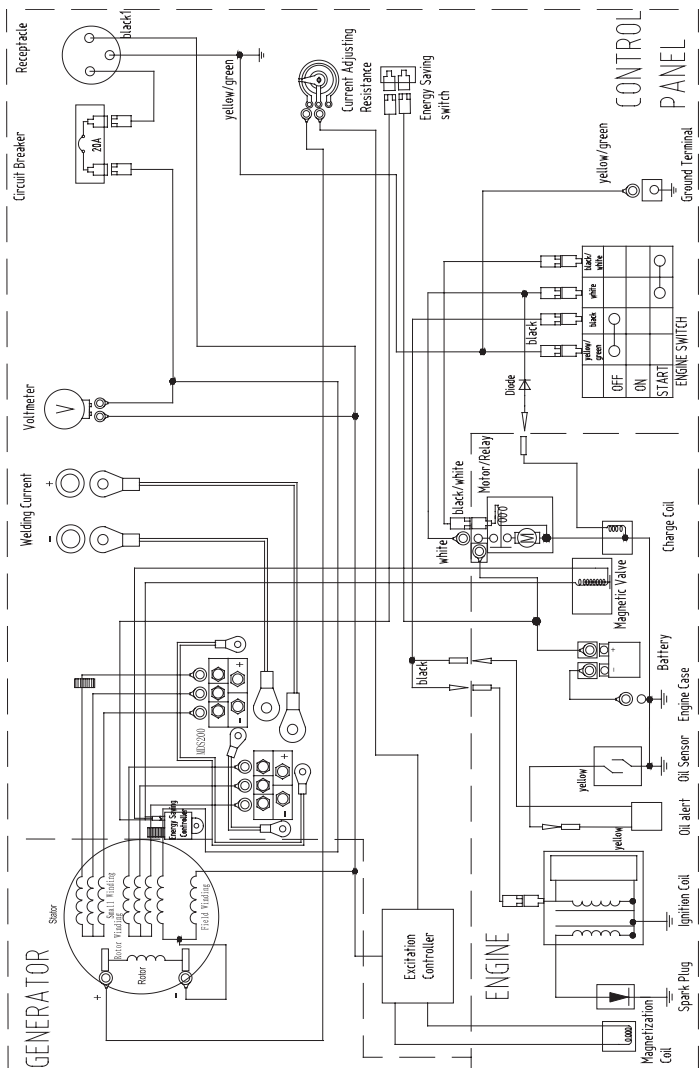

## XII. SPECIFICATIONS

	Items	RTAXQ1-190	RTAXQ1-190D	RTAXQ1-190-2
Welder	No load voltage (V)	80	80	≥60
	Rated welding voltage(V)	27	27	27
	Welding current (A)	190	190	190
	Frequency (Hz)	720	720	60
	Cyclic duration factor	100%	100%	100%
	Auxiliary power supply(V/kW)	220/3(DC)	220/3(DC)	230/3.5(AC)
	Current adjusting (A)	50-190	50-190	50-190
	Welding rod(mm)	2-5	2-5	2-5
Engine	Model	R390	R390-3	R420
	No load speed(r/min)	3600	3600	3200
	Rated speed (r/min)	3300	3300	3000
	Displacement(cc)	389	389	420
	Valve	OHV	OHV	OHV
	Ignition mode	CDI	CDI	CDI
	Fuel tank volume(L)	25	25	25
	Minimum fuel consumption (g/kW·h)	210	210	≤374
Starting system	Recoil starter	Recoil /electric starter	Rec oil /electric starter	
Protection grade	IP21			
Insulation class	F			

Welder	Length (mm)	686	686	675
	Width (mm)	550	550	565
	Height (mm)	570	570	545
	Net weight (kg)	90	100	≤95
General purpose Accessory	Large air cleaner	●	●	●
	Large muffler	●	●	●
	Large fuel tank	●	●	●
	Fuel gauge	●	●	●
	Voltmeter	●	●	●
	Ammeter	●	●	-
	Oil alert system	●	●	●
	Circuit breaker	●	●	●
Electric Starting Accessory	-	●	●	

Remarks: ● means available, - means unavailable

### **XIII. WHEEL (OPTION)**

1. Install the two wheels on the wheel axle with gaskets and pins.
2. Install the wheel set on the bottom plate of the welder frame with bolts and nuts.

