

FICHA TÉCNICA

Conector De Vitrinas De 2 Vias.

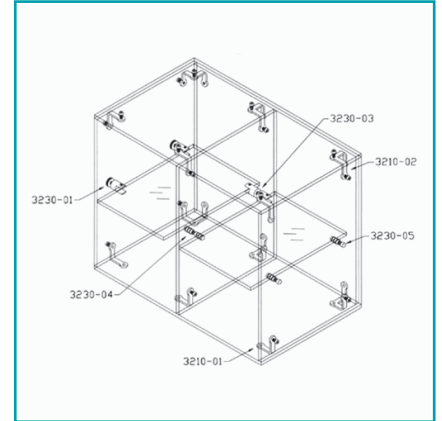

CÓDIGO:
C-3210B-01

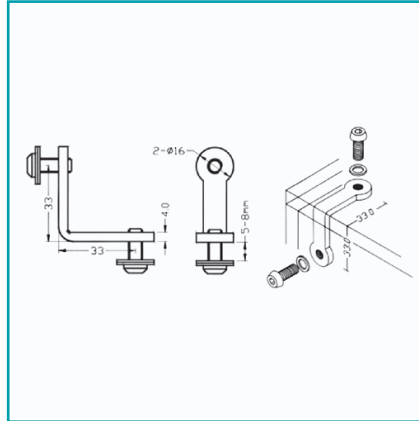

Código de producto: C-3210B-01

Marca: ARMSTRONG

Peso (Kg): 0.04 Kg

Tipo: Vitrina Vidrio Templado

INFORMACIÓN ADICIONAL

Conector De Vitrinas De 2 Vias.

