



FICHA TÉCNICA

Producto: **Motor de cortina metálica enrollable de 600Kg**

DESCRIPCIÓN: Motor de cortina metálica enrollable de 600Kg, de Carbone Automatismos, con una velocidad de rotación del motor de 5.3 R/Min, altura máxima de elevado de 6 metros y una potencia de 370W un total de peso máximo por puerta de 600Kg. Incluye: 2 controles learning code y 1 operador manual. Funciona con un máximo de 30 controles. Con una garantía de dos años.

CÓDIGO: MV01

Instalación



Marca: Carbone Automatismo

Potencia: 370W

Voltaje: 110V 60Hz

Rotación: 5.3 R/Min

Peso de levante máximo: 600 Kg.

Altura máx. de levantado: 6M

Cilindro estándar: 4' pulgadas

Fuerza de elevación: 600KG.F

Temperatura de trabajo: -20~41°C

Incluye: 2 controles learning code y 1 operador manual.

Máximo controles: 30 controles

KIT INCLUYE

2 controles learning code



Operador manual



Nota:

Funciona para un máximo de 30 controles.

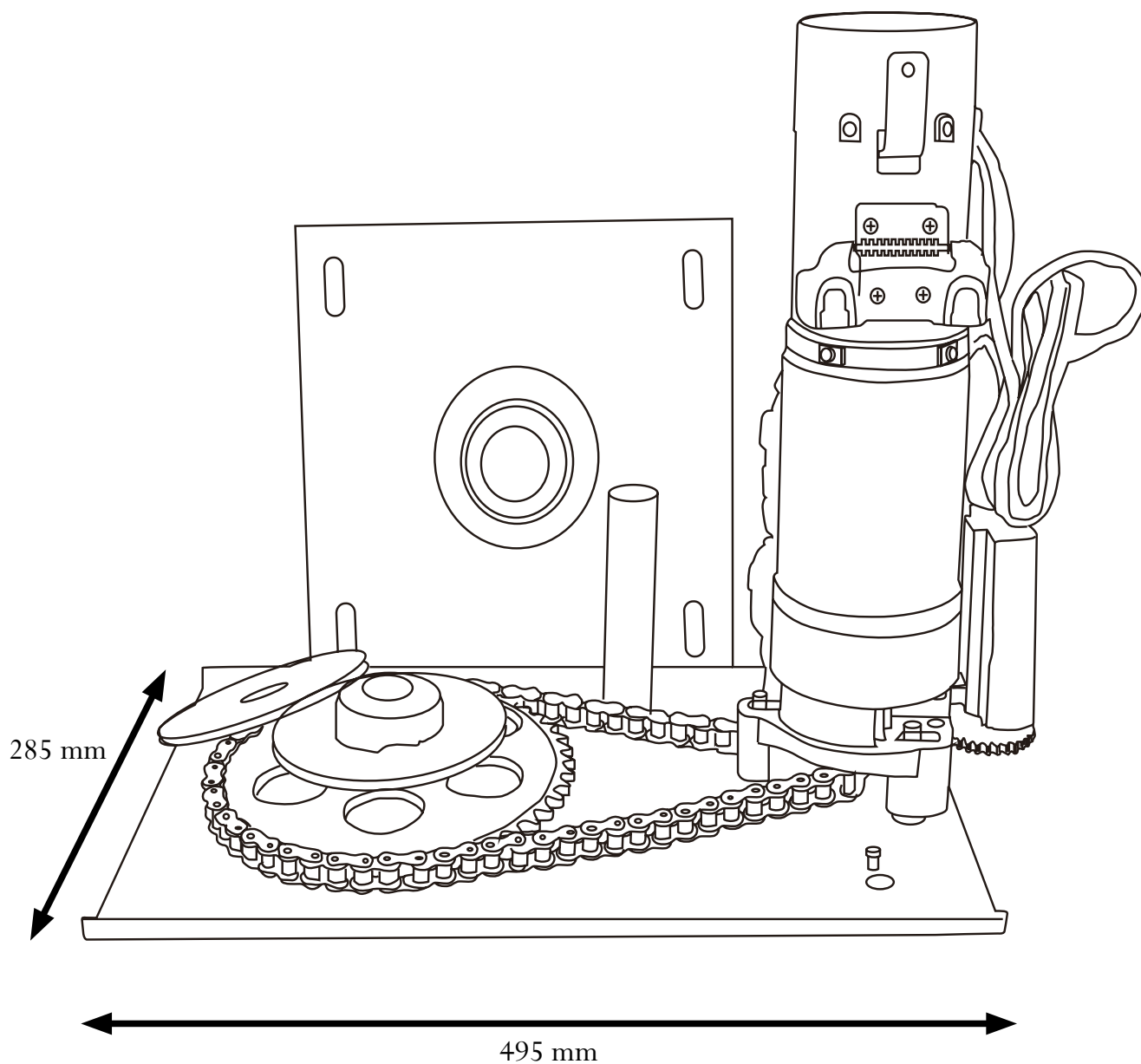



600^{kg} 
MVO1

1000^{kg} 
MVO2

ROLLING SHUTTER MOTOR

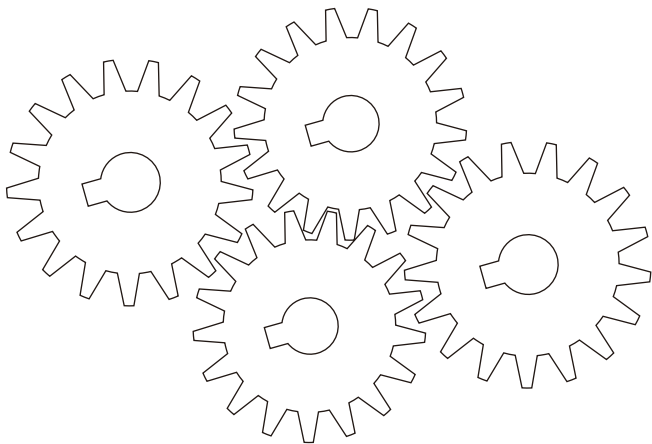



Rolling shutter motor

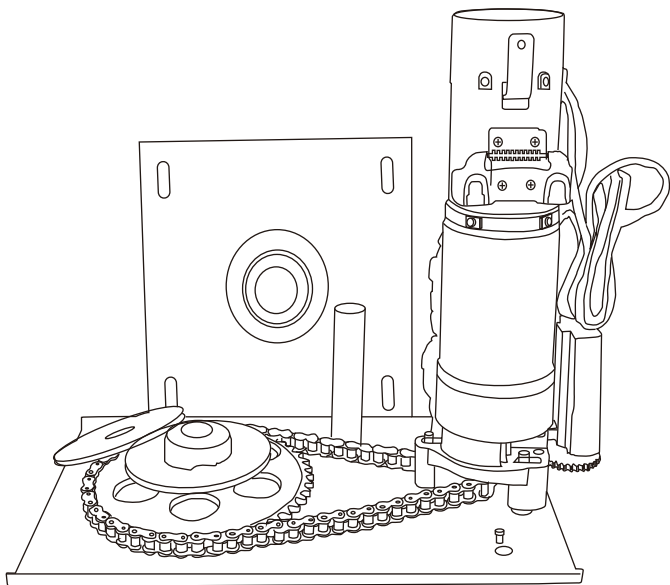



OPERATION MANUAL ROLLER SHUTTER MOTORS

The manufacture of the Carbone Series Motors utilizes most advanced production techniques combined with the latest technologies available to provide reliability with diverse functionality. They are simple to install and are proven to be ideal accessories to a wide variety of applications.

Carbone Series Motors can be installed to both Left and Right sides of openings and can be equipped for direct-wiring and remote-control operations when power is disconnected or temporarily unavailable therefore making them ideal for installations in areas subject to frequent power cuts.

I. Work Environment and Conditions

- 1. Working temperature : -40 to 60**
- 2. Relative working humidity : 90% at 25**
- 3. Short-term working :**
 - a. Continual Single-Phase operation should not exceed 7 minutes**
 - b. Continual Three-phase operation should not exceed 10 minutes**

II. Main Specifications and Technical Parameters for Standard and 'F' Type

Model	Power (w)				Max lifting height (m)	Max external diameter of door (m)	Chain NO.	Weight of the main machine (kg)	Carton (cm)	
		Lifting force (kg.f)	Output torque N.m	Output turn Speed r/min					Motr	Bracket
		110V			60HZ					
MVO1	370	600	412	5.3	6	0.48	10A	10		
MVO2	550	1000	809	3.6	9	0.54	10A	15		

Note: 'F' = Fire Safety Models

Product Characteristics

- Simple pleasing design of structure
- Good drive/size ratio
- Selected elements ensure safe working and reliability
- Low noise
- Small oscillation
- Lightweight
- Safety Device in of chain-break



III. Installation & Testing

1. The Carbone Series Motors are produced for standard mounting to the right of the opening (viewed from inside). If you wish to install to the left side, it is necessary to loosen the bolts on the brake-shell. This will allow you to turn the shell 180° and then re-tighten the bolts

Note: The white and green lines of the switches should change positions.

2. The support board of the chain-wheel can be installed horizontally, according to the specific situation-as shown in Fig.3-or it can be fixed within a range of 0-45 degrees. When the support board is not installed horizontally the brake-shell must be turned so that the loop-type hand-pull chain can lie vertically in a normal manner.

Note: Special attention must be given to the joint of the shell-body and the top cover of the motor. When you are certain that there is no gap then tighten the bolts (diagonally). If a gap exists, and is allowed, the braking efficiency could be affected.

- The roller shutter door motors should be installed exactly horizontally.
- The roller axle of the shutter should door should be homocentric and horizontal
- The roller shutter should be free of any obstructions.
- The vertical hanging length of the chain must be adjusted within 3-6mm-adjustment should be made before hanging the shutter onto the roller axis.
- It is strictly forbidden to pull on the motor down lead.
- External power cord should be minimum 1mm diameter.
- Special attention should be given to protecting the motor from humidity and rain, to prevent short-circuiting.

The phase order must not be violated for three-phase motors. When the rise-up becomes downside the motors must be immediately stopped for readjustment of the phase order .If an interim power source is used for testing, attention should be given to connect in correct sequence when normal power source is introduced.

The correct operation approach is that when the rise-up button on the White line is pressed, the motor should turn anti-clockwise, allowing the position limiting device to function-see Fig .1 for details. Otherwise the shutter door would be out of control and will be damaged.

The motor must be satisfactorily earthed to prevent potential injury from shocks. The earthing connection bolts should be fixed to the chain wheel support board OR electric appliance control box.



Position Limiting Diagram

Fig.1 When the motor is to be fixed on the left

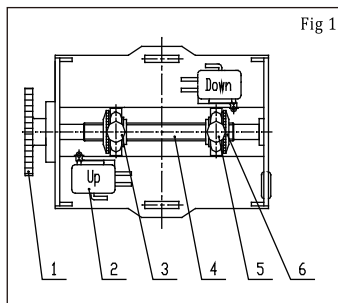

Serial Number	1	2	3	4	5	6
Name	Position limiting gear	Jogging switch	Locking bolt	Gearing wire	Position limiting screw nut	Position limiting slide piece

Drum install Diagram

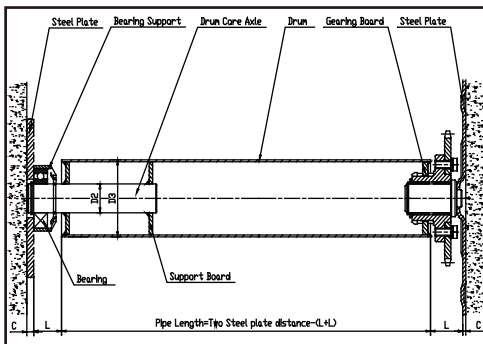

Fig 2



Model	D2	D3	L	C	Axle	Remark
600Kg	Φ35	5"	35	4	207	
1000Kg	Φ40	6"	45	5	208and1208	

Note: Right side install, DI Shutter Door Motor Model

Support Plate Install Diagram

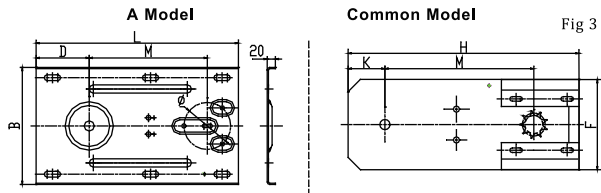
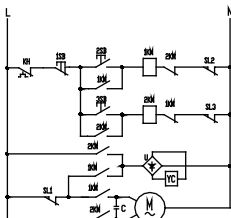

Fig 3

Model	L	B	M	D	Φ
600kg	495	285	289	130	114.5
1000kg	640	370	340	170	200

Position Limiting Diagram

Carbone Series 110 V Electric Wiring Diagram

Symbol	Name	Size & Model	Quantity
KH	Heat Protector	JOK—SF—1	1
1SB- 2SB- 3SB	Switch	2 open, 1 close	1
SL1- SL2- SL3	Top and bottom Buttons	JWL—1—11	3
1KM- 2KM	Small relay	CJXZ—6.3/0.1	2
C	Capacitor	16-30 μ f 450VAC	1
U	Rectifier		1
YC	Magnet coil		1
M	Single—phase Motor	~220V	1

(300kg—1000kg)

Carbone Series 110 V Electric Wiring Diagram

Symbol	Name	Size & Model	Quantity
KH	Heat Protector	JOK—SF—1	1
1SB- 2SB- 3SB	Switch	2 open, 1 close	1
SL1- SL2- SL3	Top and bottom Buttons	JWL—1—11	2-4
1KM- 2KM	Small relay	JQX—13F	4
C	Capacitor	16-30 μ f 450VAC	1
U	Rectifier		1
YC	Magnet coil		1
M	Single—phase Motor	~220V	1

(300kg—1000kg)

Tianyi Series 380V Electric Wiring Diagram

Symbol	Name	Size & Model	Quantity
KH	Heat Protector	JOK—SF—1	1
1SB- 2SB- 3SB	Switch	2 open, 1 close	1
SL1- SL2- SL3	Top and bottom Buttons	JWL—1—11	2-4
11K—4K	Small relay	JQX—13F	4
U	Rectifier		1
YC	Magnet coil		1
M	Single—phase Motor	~380V	1

(300kg—1000kg)

(with white mark) black (zero)

(No mark) black (fire)

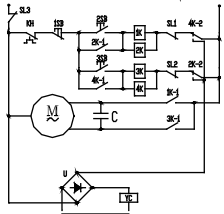

A B C

red green yellow black/red/blue

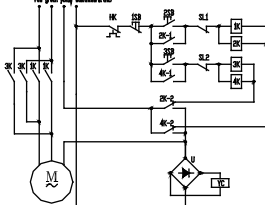

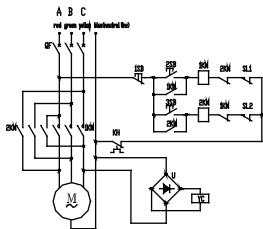

Tianyi Series 380V Electric Wiring Diagram

Symbol	Name	Size & Model	Quantity
KH	Heat Protector	JOK—SF—1	1
1SB. 2SB. 3SB	Switch	2 open, 1 close	1
SL1. SL2. SL3	Top and bottom Buttons	JWL—1—11	2-4
1KM. 2KM	Small relay	CJXZ—6.3/0.1	4
U	Rectifier		1
YC	Magnet coil		1
M	Single—phase Motor	~380V	1

(1300kg—2000kg)

IV. Usage

Press “UP” or “down” buttons .If there is no reaction—press the “stop” button to avoid potential damage to the motor.

Check to see if there is any blockage under the shutter door before closing it. Passage under the shutter is forbidden during the process of starting or closing the door.

When closing the shutter, with the power off, lightly pull on the shutter door loop for slide—down at even controlled speed.

Relax the pull on the on the pulling loop when the door is almost closed and then pull again to close it completely.

Motors for fire shutter doors are equipped with separate control boxes—specially qualified personnel should undertake regular and preventative maintenance and inspection.

Single-Switch Control

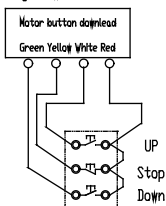

Double-Switch Downteard

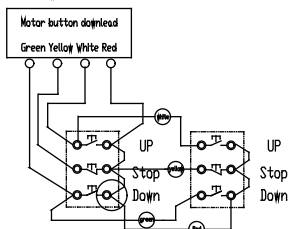

■ The above is right-side installation-see Connection diagram; change the position of white and green lines in left-side installation

Remote Controller and Shutter door Motor (Switch) Connection

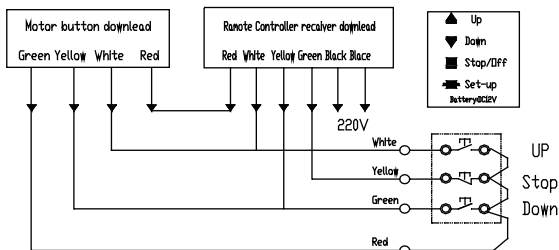

- See Connection diagram for right-side installation; change the position of white and green lines for left-side installation
- Uncover the pipe at the middle of the button line, -Cut off yellow line to uncover lead line, and connect them separately.

V. Trouble shooting

Problem	Analysis	Solution
No stop at upper and bottom positions	Incorrect connection of phases, and the position fails	Cut off power, check, adjust and change
Up only, or down only	Circuit contact fails, over low voltage<185v, Electromagnetic iron weak in attraction force	Polish contact or change relay, adjust voltage button contact, change magnet coil
No reaction	Button contact fails, position limiting switch contract fails, \circuit cut off	Adjust and change joggling limiting switch and relay
Non-stop Operation	Relay contact fused, joggling switch out of control	Repair or change joggling switch and relay
Non-operation, only noise	Machine blocked, voltage too low	Remove block, adjust voltage



VI. Type Selection Formula

Output torque T

Total weight of shutter door G-----= Motor type –total lifted weight Kg
 Radius of rolling axle R×9.8

G=door material/m2×length ×width (see attachment for details)

Material	Kg ×m2
Aluminum alloy	5-6
Mesh door	12
Powder coated steel	8-14
Stainless steel	10-18
Fire prevention door	25-36

Single-phase shutter door motor has obvious fluctuations of voltage, and therefore attention should be paid to voltage in type in type selection.

VII. Shutter Door Axle

When the door is more than 5m in width, with more than 3 mm thickness and self-weight is above 350kg, 5 seamless pipe with more than 3mm thickness and zinc plated must be used to prevent pipe axle from bending which would lead to overload and a short life of motor, and even directly damage teeth of motor's gear.

VII. Motor Accessories:

- Chain wheel support ,
- big chain wheel (including axle connect);
- roller chain ;
- drum core axles;
- axle and axle support ;
- gearing board ;
- support board ×2;
- button/switch;
- 3 meters of button/switch line;
- switch box.

IX. Warranty Period

One year from the day of shipment; parts are offered at preferential prices.

X. Option

- Wireless remote controller
- UPS electricity storage device AT (220)