

FICHA TÉCNICA

Araña Fitting 1 Via.

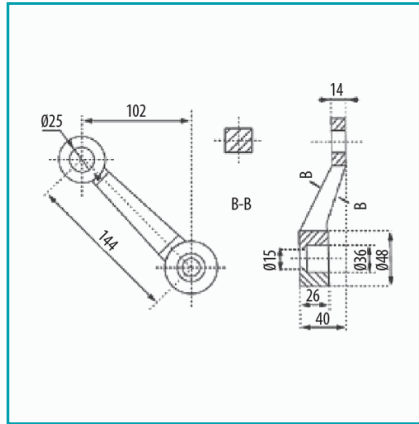

CÓDIGO:
FS2041L



Código de producto: FS2041L

Marca: CARBONE

Peso (Kg): 0.68 Kg

Tipo: Sistema Fachada Arañas

INFORMACIÓN ADICIONAL

Araña Fitting 1 Via.

