

Automated Vehicular Yoga Boom Gate System

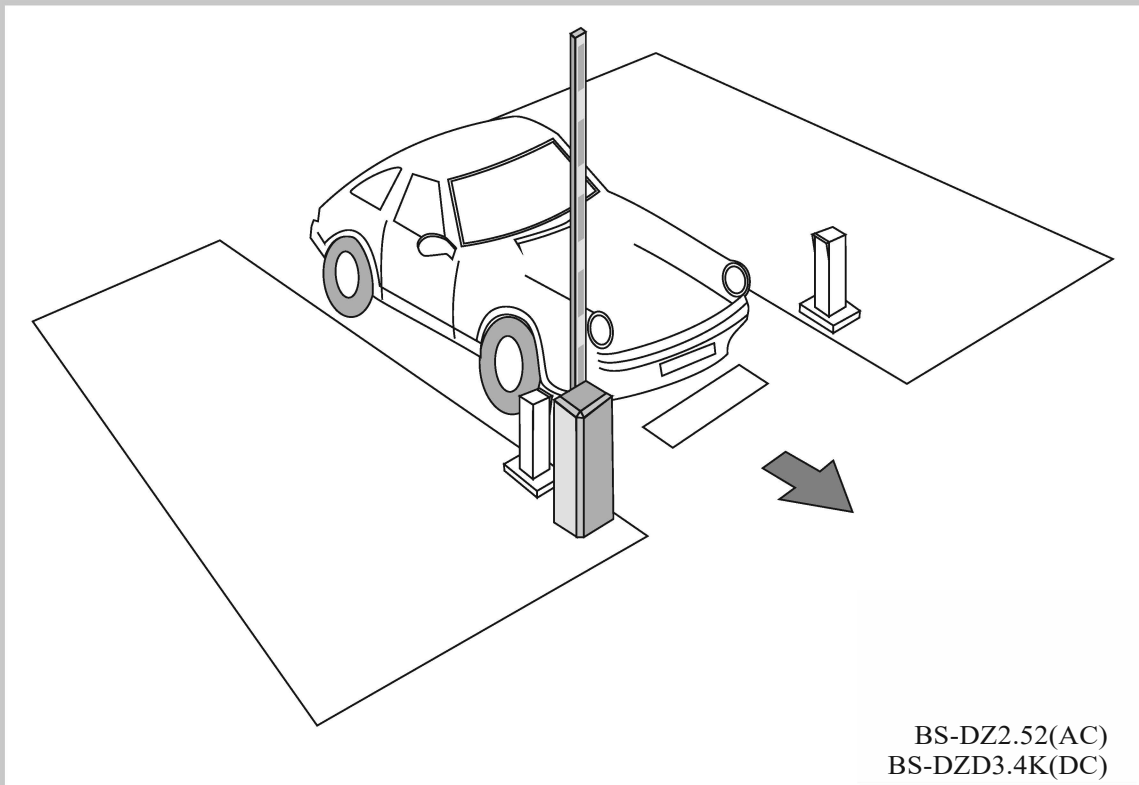

Installer and User' s Manual
Please read carefully before using



Automatic Boom Gates are not for Pedestrians!

Automatic gate openers are designed for vehicular traffic. They are powerful and can cause serious bodily injury or death. Accordingly, direct all pedestrian traffic to a separate walk-through gate.

1. Before starting installation and operation or maintenance, cut off power supply.
2. The product must be earthed, And an earth leakage breaker is necessary on the power supply.
3. As for electric cable type and section, we suggest to use the cable type of <HAR> with minimum section of 2.0mm²
4. Do not change the original inside wiring.
5. If power failure, please switch off the power supply first, then open the door and rotate the handle on the motor manually to open the boom completely.
6. Keep the automatic control (push-button, remote control, etc) out of the reach of children. The control system must be installed at a minimum height of 1.5m from the ground surface.
7. Use transmitters or button only where you can see the gate clearly.
8. Never open the door or the cover of the cabinet when the machine is working.
9. Do not permit children to play on or around a gate.



**Automatic Gates are
Not for Pedestrians!**

Automatic gate openers are designed for vehicular traffic. They are powerful Accordingly, direct all pedestrian traffic to a separate walk- through gate.

A. Technical specifications

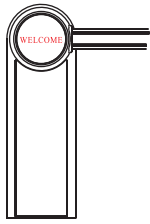

BS-106

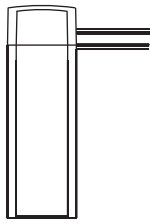

BS-206

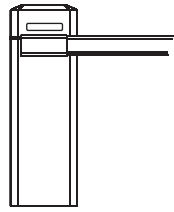

BS-306

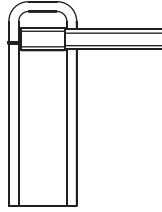

BS-606

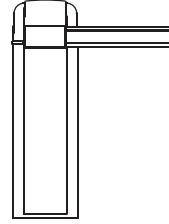

BS-806

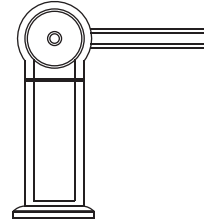

BS-906

AC series

Power supply 220VAC 50Hz / 110VAC 60Hz

Motor's power: 90WAC

Max length of Boom: 5M

1.6S(for 1-2M)

4S(for 3-4M)

Time of Up/Down: 6S(for 5M)

Working environment: -20°C--50°C

Protection class: IP55

Noise: <65db

DC series

Power supply 220VAC 50Hz / 110VAC 60Hz

Motor's power: 80WDC

Max length of Boom: 5M

1.6S(for 1-2M)

4S(for 3-4M)

Time of Up/Down: 6S(for 5M)

Working environment: -20°C--50°C

Protection class: IP55

Noise: <65db

BS-TI

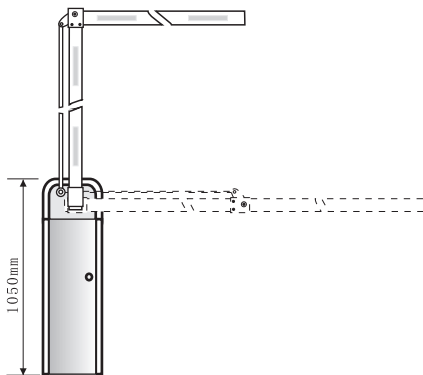

BS-TII

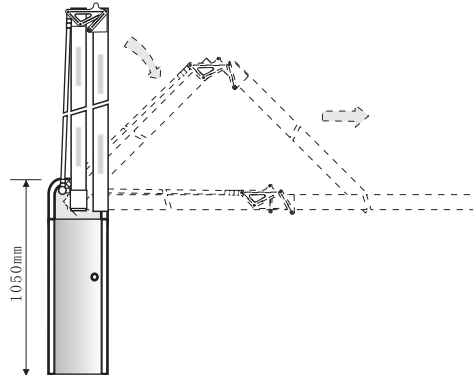

BS-TIII(A)

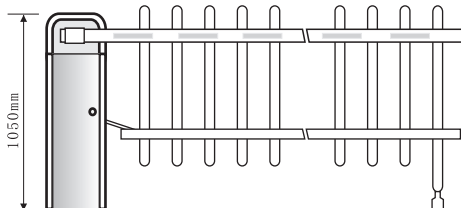

BS-TIII(B)

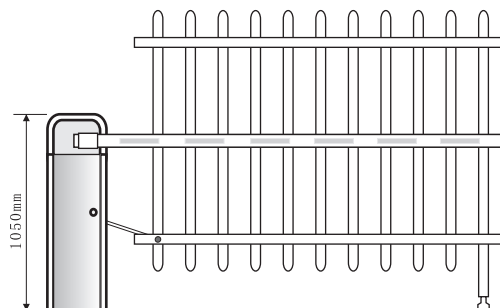

B. Installing and adjusting

1. Install the machine on the ground

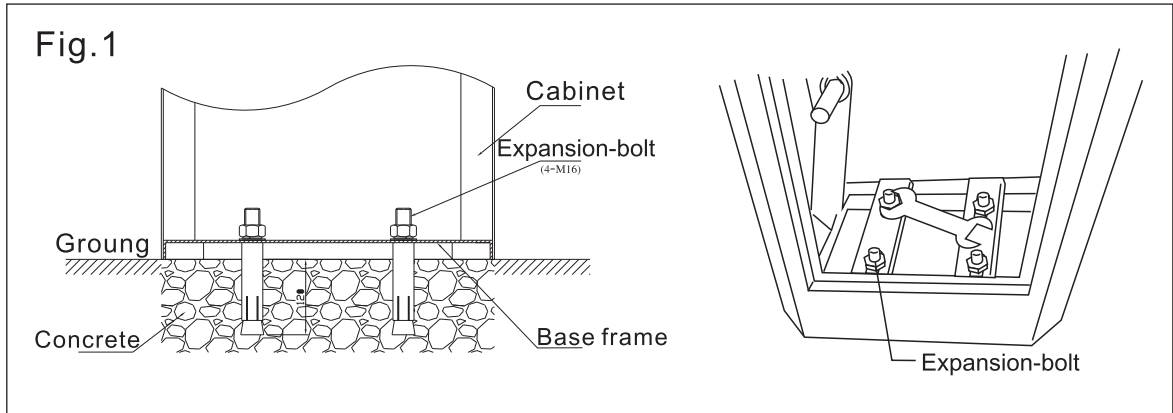

2. Install boom (Fig.2)

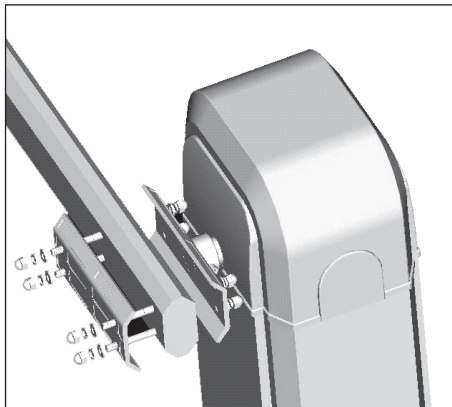

Fig.2

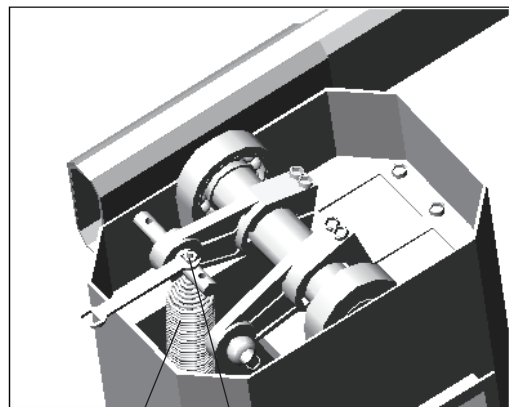
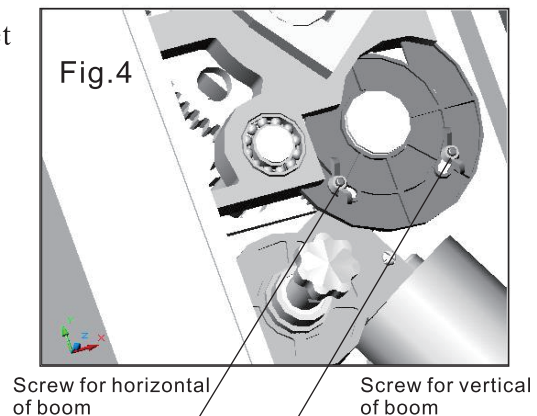

Fig.3

3. Adjust the limit position

BARRIER is supplied to you with the magnet limit switch and the mechanical limit switch that are already set to allow optimum boom movement. Do not change the limit position.



C. Quick release function (Fig.5) _____

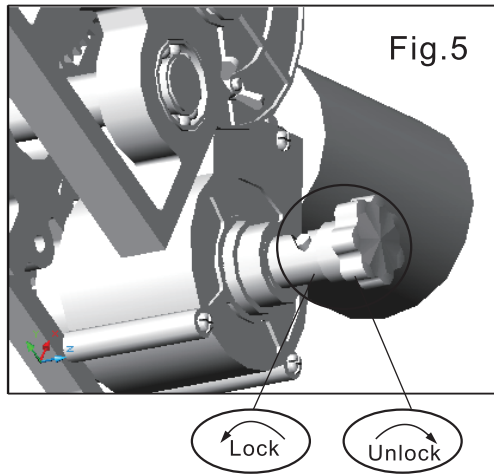

D. Adjust the vertical and horizontal line of the Boom. _____

1. Boom need to be shorter _____

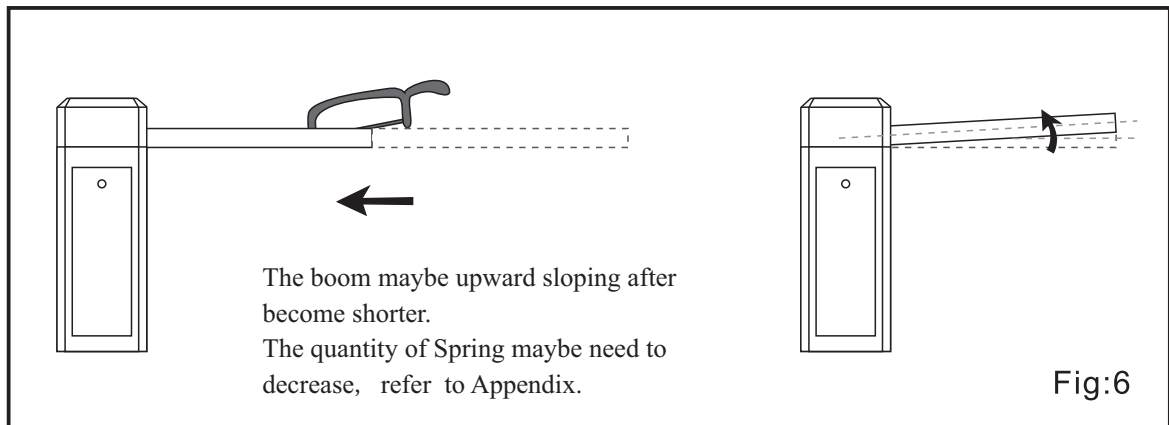

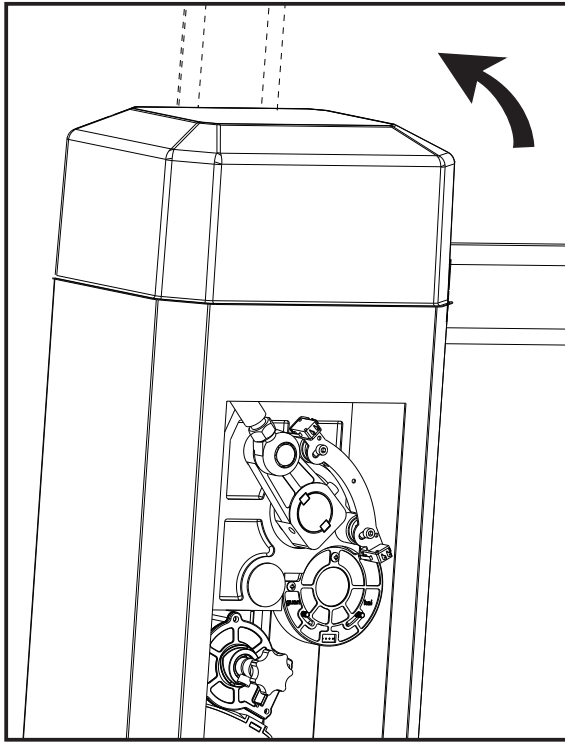

Put up the boom vertical by hand.

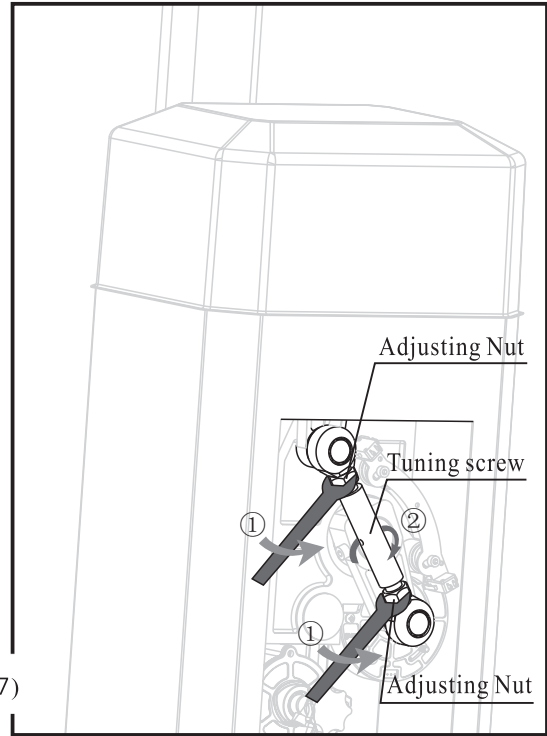

(Fig.7)

1. Loosen the Adjusting Nuts.
2. Adjust the Tuning Screw and see the Boom, if the Boom is perpendicular to the ground when it is open, tighten the Adjusting Nuts.

2. Boom need to be longer

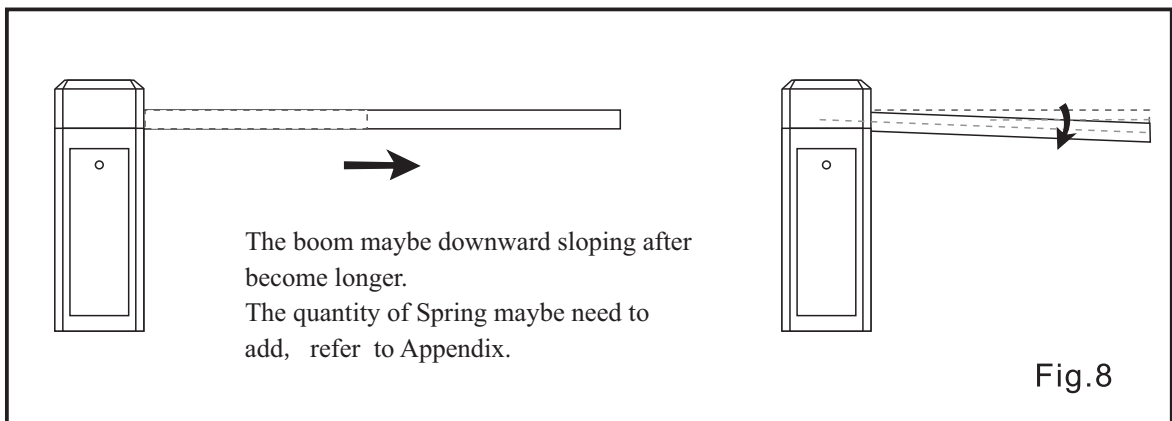
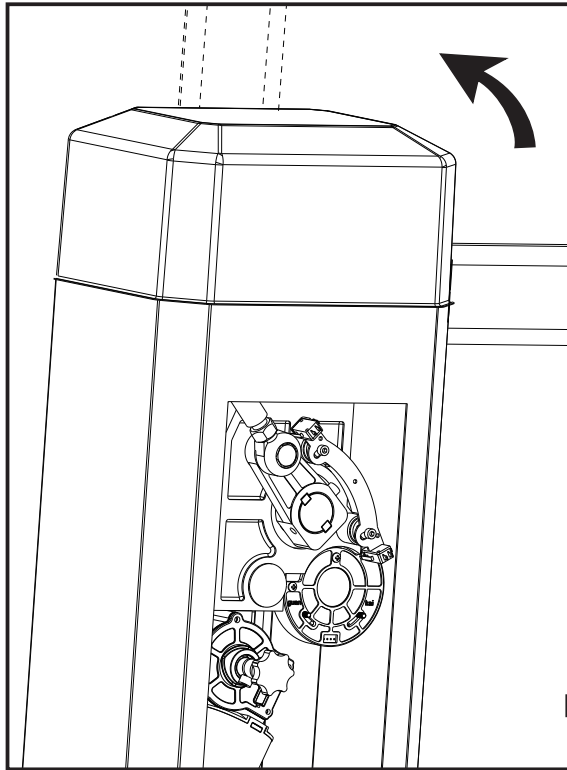

Fig.8



Put up the boom vertical by hand.

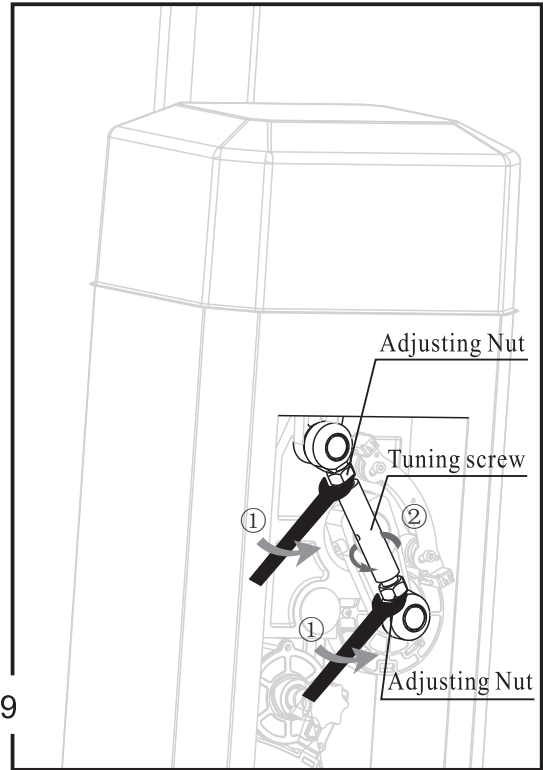

Fig.9

1. Loosen the Adjusting Nuts.
2. Adjust the Tuning Screw and see the Boom, if the Boom is perpendicular to the ground when it is open, tighten the Adjusting Nuts.



Adjust the balance of the spring with boom.

The springs have been already adjusted to balance with the boom. If the length of boom need to be changed, the springs should be re-adjusted.

See the Appendix and Fig6/Fig7/Fig8/Fig9

E. Control Board Description

1. AC Motor

Technical data:

Power supply	AC 220V 50Hz
Max. consumption	6W
Accessories power supply	DC12V 5W MAX
Environment temperature	-10℃ ~ +60℃
Frequency of remote control	433.92Mhz
Auto-close delay time	1--99S (adjustable)

General diagram:

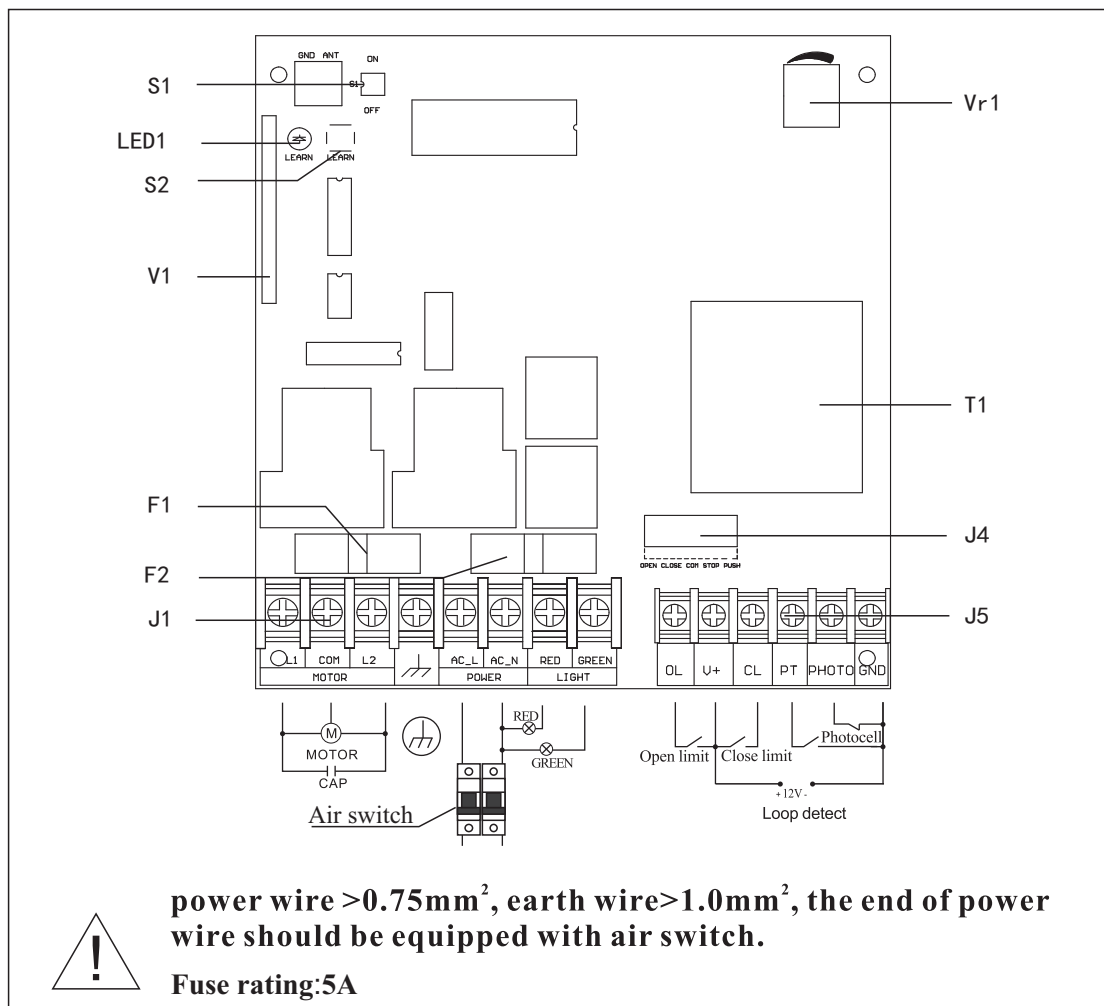

S1	Dip Switch	J1	Power terminal strip
LED1	Learn LED	J5	Low voltage terminal strip
S2	Learn Button	J4	External terminal strip
V1	Receiver	T1	Transformer
F1	10A Fuse (for motor)	VR1	Potentiometer for auto-closing delay time
F2	0.5A Fuse		

DIP Switches:



Dip1: ON: Auto-close is valid, the delay time is adjustable when rotating potentiometer.

OFF: Auto-close is cancelled.

Dip2: ON: The red light is ON when running (For Alarm light).

OFF: The red light is ON when close; the green light is on when opened (For Traffic lights).

Terminals:

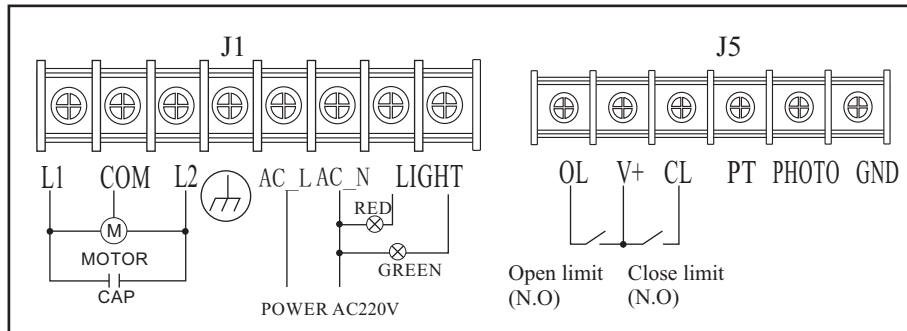

Safety Devices Connecting & Setting (3 Option): _____

a. Phtocell (N.C.) (BS-IR30) _____

- >When the gate is closing if the Infrared ray is shut off, the gate opens instantly.
- >When the gate is open, if the Infrared ray is shut off, the gate keeps open status.

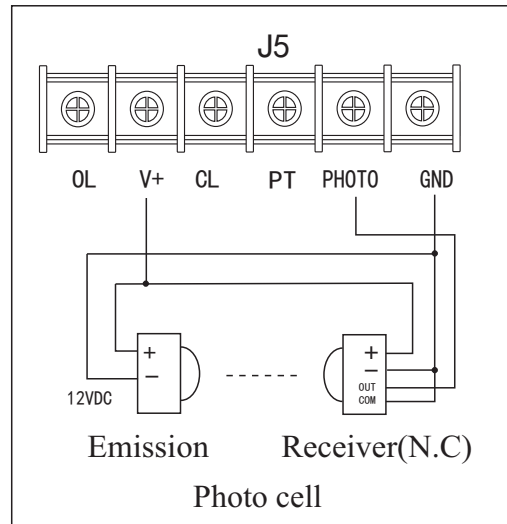

b. Loop Detector (N.C.) (BS-LD) _____

- >When the gate is closing, if a car in the range of loop, the gate opens instantly..
- >When the gate is open, if Car is in the range of Loop, the gate keeps open status.

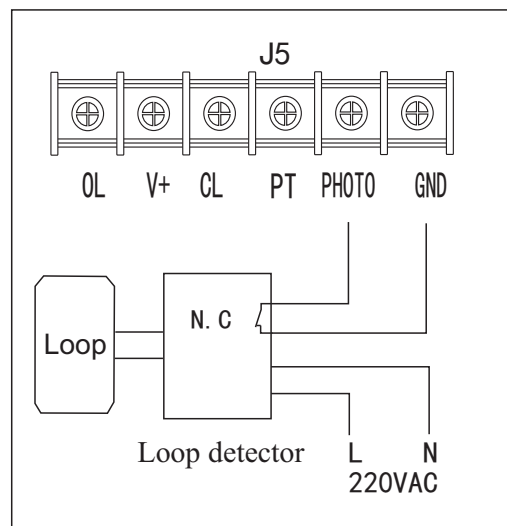

Note: If Auto-closing function is valid, When a vehicle pass through the sensor range, the gate will close automatically after delay time, The delay time can be adjusted from 1--99 seconds.

c. Loop Detector (N.O.) (BS-LD)

- >If a car is in the range of sensor, the gate is open.
- >When a car left from the rang of sensor, the gate closes instantly
DIP1 should off.

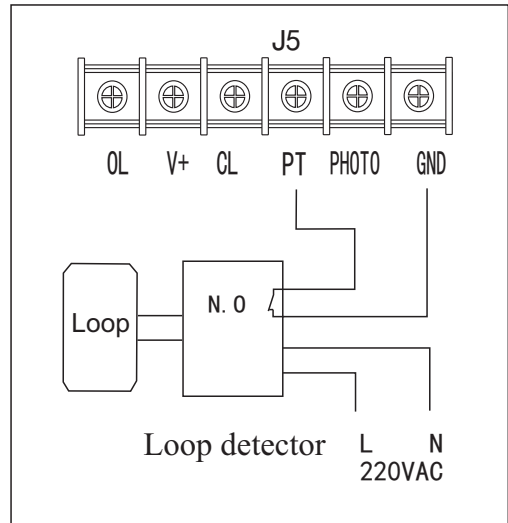

External terminals:

- >When a CARD READER or a Push Button is used, it must be connected with OPEN and COM.
- >"Push" is for single Button, works in "Step--by--Step" way. Press button to close in Open position, Press Button to open in Close Position, Press Button to stop in Opening operation, Press Button to open in Closing operation.

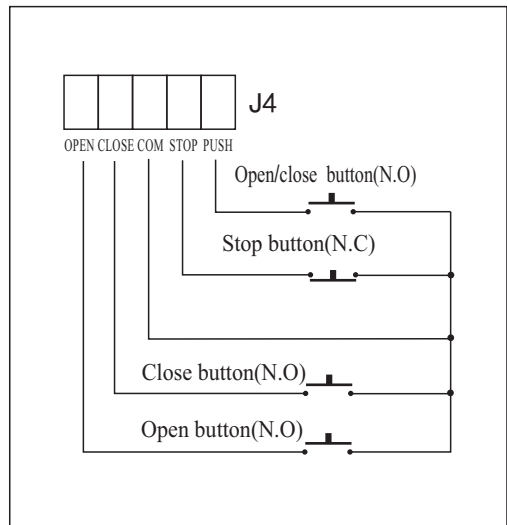

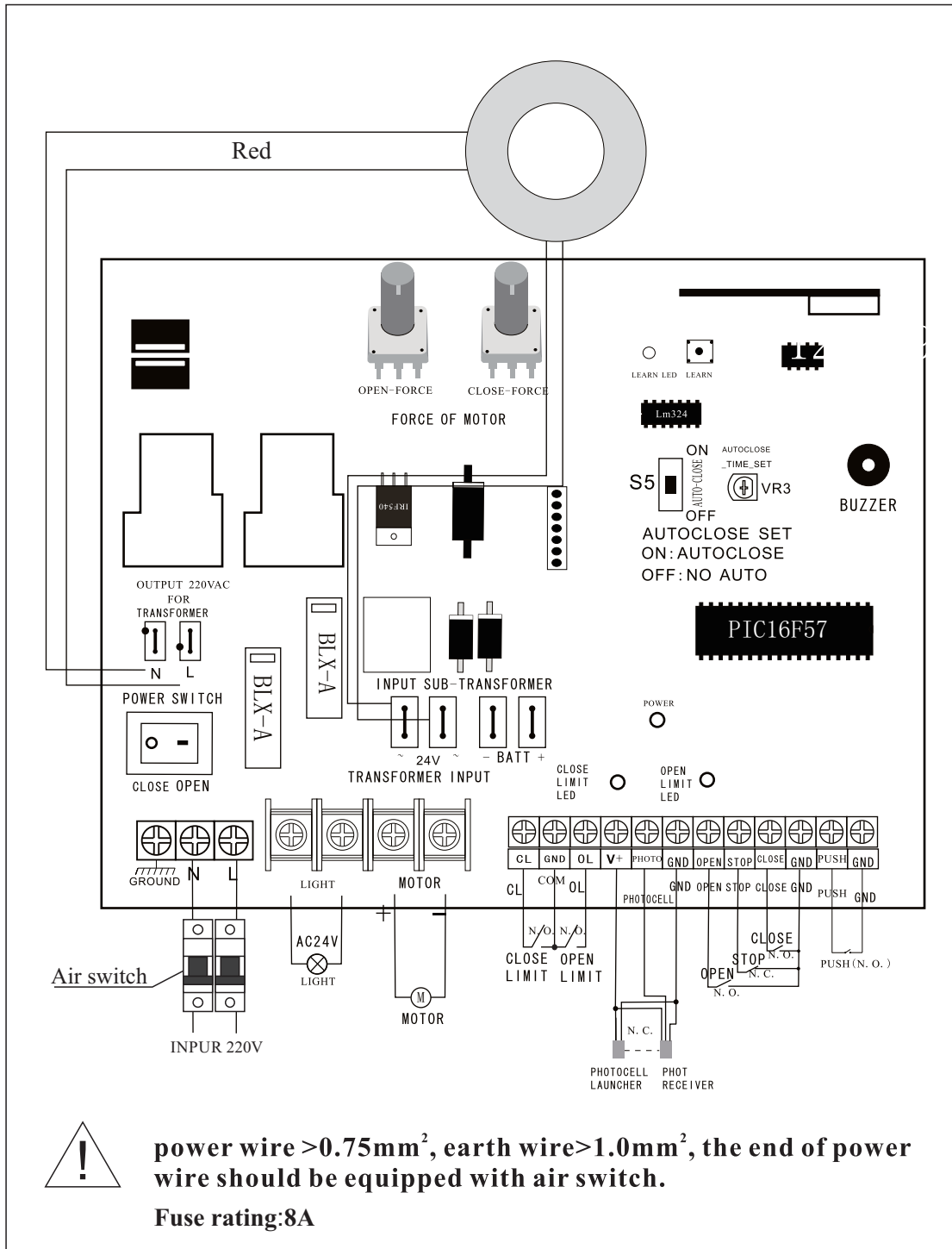

2. DC Motor

General diagram:

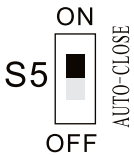
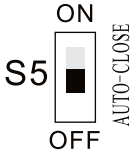

DIP switch: _____

 <p>S5</p>	<p>“ON”, Auto-close function is enabled.</p>
 <p>S5</p>	<p>“OFF”, Auto-close function of is cancelled.</p>
<p>AUTOCLOSE _TIME_SET</p>  <p>VR3</p>	<ul style="list-style-type: none"> ● If the DIP is “ON” (auto-close enabled), the auto-close delay time can be adjusted by this variable resistor. ● To add is clockwise, to reduce is counterclockwise.

Force of Open and Close: _____

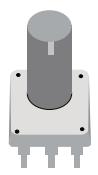
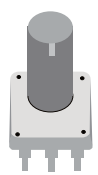
 <p>OPEN-FORCE</p>	<ul style="list-style-type: none"> ● Adjust the force of opening boom by the variable resistor. ● To add is clockwise, to reduce is counterclockwise.
 <p>CLOSE-FORCE</p>	<ul style="list-style-type: none"> ● Adjust the force of closing boom by the variable resistor. ● To add is clockwise, to reduce is counterclockwise.

Safety Devices Connecting & Setting (4 Option):

a. Photocell(N.C.)

- >When the barrier is closing, if the photocell ray is shut off ,the barrier opens instantly.
- >When the barrier is Open, the barrier keeps OPEN status if the Photocell ray is shut off.

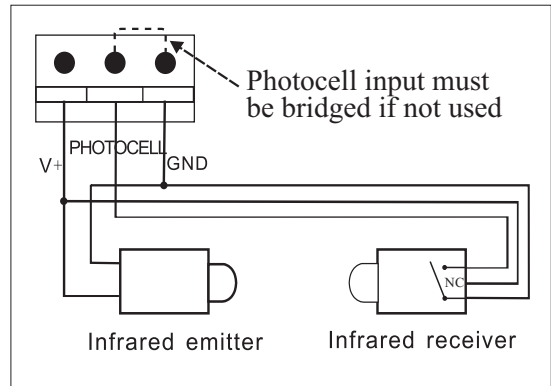

b. Loop Detector(N.C.)

- >When the barrier is Closing, if a car is in the range of sensor, the barrier opens instantly.
- >When the barrier is Open, if a car is in the range of sensor, the barrier keeps OPEN status.

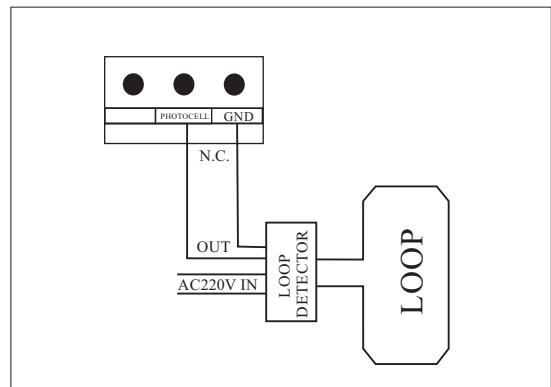

c. Photocell(N.O.)

- >When the barrier is Closing, if the photocell ray is shut off ,the barrier opens instantly.
- >When the barrier is Closed, if the photocell ray is shut off ,the barrier opens instantly.
- >When the barrier is Open, the barrier keeps OPEN status if the Photocell ray is shut off.

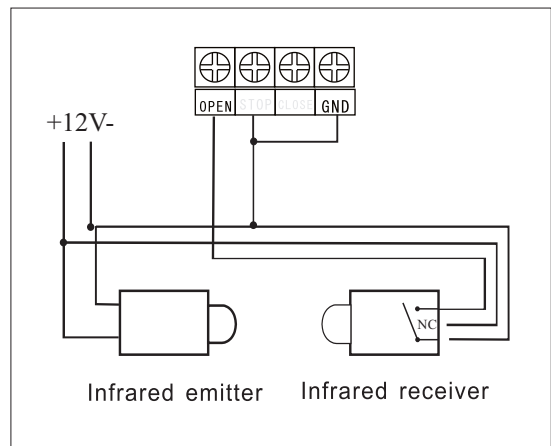

d. Loop Detector(N.O.)

- >When the barrier is Closing, if a car is in the range of sensor ,the barrier opens instantly.
- >When the barrier is Closed, if a car is in the range of sensor ,the barrier opens instantly.
- >When the barrier is Open, the barrier keeps OPEN status if the Photocell ray is shut off.

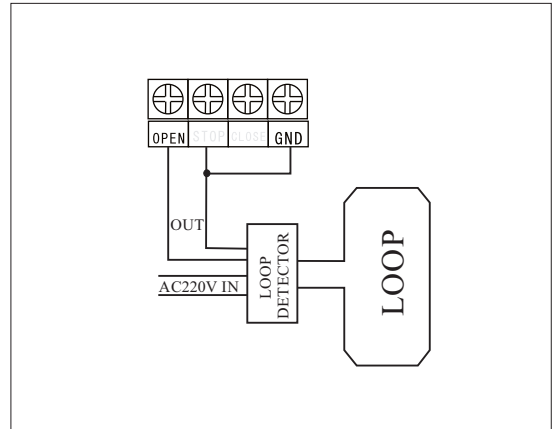

E. Setting transmitter code:

Press "LEARN BUTTON" once,the "LEARN LED" light, then, press the button you choose on transmitter till the "LEARN LED " flash and go out.

Now, the transmitter is coded, Other transmitters can be coded as this way.

F. Erasing transmitter codes:

Press"LEARN BUTTON" and hold on to make the "LEARN LED"light till go out.

Now, all codes of transmitters which had been learnt are cleared.

G. standard installation layout

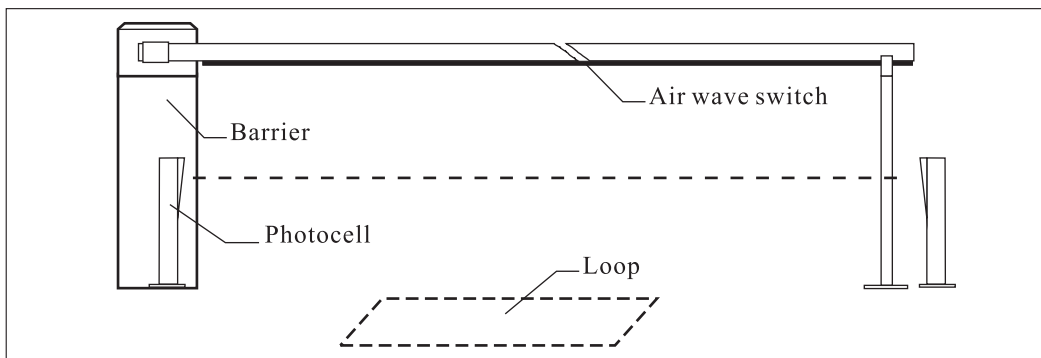

H. Trouble Shooting

Number	Trouble	Cause	Shooting
1	motor dose not work	*No power supply *Break fuse *Motor is damaged	*Check power supply *Change fuse *Change the motor
2	Can open but can not close	*Photocell is not connected properly *Photocell beam is block off. *Photocell is broken.	*Connect the photocell properly *Clear out obstacle *Change a new device
3	Can open (close) but can not close (open)	*Position of limit switch is not correct *Limit switch is damaged	*Adjust position *Change limit switch
4	can not locate accurately	*Distance of limit switch is too large *Limit switch is wrong *Magnetic- steel's position is wrong	*Adjust position of limit switch *Change limit switch *Re-adjust the position
5	Release device is doesn't work	*Operating handle is broken *Worm gears are jammed	*Change the handle *Rotate the pinion
6	Push the "OPEN" button but the gate close	*Whether "+MOTOR-" wires are connected wrong	*Connect correctly according to wiring diagram
7	Motor can work but boom can not work	*Compression spring of clutch is dead	*Change the spring

I. Appendix

Table of spring quantity and size with Boom's length

Model	Boom Length	Quantity of Spring	Spring's size
BS-106 BS-206 BS-806 BS-906	≤3-4M	1	φ5×440mm
	≤4-5M	2	φ5×440mm
	≤5-6M	2	φ5/φ6×440mm
BS-I/II-206 BS-I/II-806 BS-I/II-906	≤3-4M	1	φ5×440mm
	≤4-4.5M	2	φ5/φ6×440mm
	≤4.5-5M	2	φ5×440mm
BST-III(A)-106 BST-III(A)-206 BST-III(A)-806 BST-III(A)-906	≤3-4M	2	φ5×440mm
	≤4-4.5M	2	φ5/φ6×440mm
	≤4.5-5M	2	φ6/φ6.5×440mm
BST-III(B)-106 BST-III(B)-206 BST-III(B)-806 BST-III(B)-906	≤3-4M	2	φ5×440mm
	≤3-4M	2	φ6×440mm
	≤3-4M	2	φ6.5×440mm
BS-306	≤3-4M	1	φ5×440mm
	≤4-5M	2	φ5×440mm
	≤5-6M	3	φ5×440mm
	≤6-7M	4	φ5×440mm
BST-I/II-306	≤3-4M	2	φ5×440mm
	≤4-4.5M	2	φ5/φ6×440mm
	≤4.5-5M	3	φ5×440mm×2 φ6×440mm
	≤5-6M	4	φ5×440mm
BST-III(A)-306	≤3-4M	2	φ5×440mm
	≤4-4.5M	2	φ5/φ6×440mm
	≤4.5-5M	4	φ5×440mm×3 φ6×440mm
	≤5-6M	4	φ5×440mm φ6×440mm×3
BST-III(B)-306	≤3-4M	2	φ5×440mm
	≤4-4.5M	3	φ5×440mm×2 φ6×440mm
	≤4.5-5M	4	φ5×440mm×3 φ6×440mm
BS-606	≤3-4M	1	φ5×440mm
	≤4-5M	2	φ5×440mm
	≤5-6M	3	φ5×440mm
BST-I/II-606	≤3-4M	1	φ5×440mm
	≤4-4.5M	2	φ5/φ6×440mm
	≤4.5-5M	3	φ5×440mm×2 φ6×440mm
	≤5-6M	3	φ5×440mm φ6×440mm×2
BST-III(A)-606	≤3-4M	2	φ5×440mm
	≤4-4.5M	2	φ5×440mm φ6×440mm
	≤4.5-5M	3	φ5×440mm×2 φ6×440mm
	≤5-6M	3	φ5×440mm φ6×440mm×2
BST-III(B)-606	≤3-4M	2	φ5×440mm
	≤4-4.5M	3	φ5×440mm×2 φ6×440mm
	≤4.5-5M	3	φ5×440mm φ6×440mm×2

