





TOTAL

说明书材质要求:105g铜版纸	说明书成品尺寸: 182x257mm
第一:专色+CMYK油墨要求: 1.TOTAL专色油墨, 见实物色样调整 2.C色油墨:泗联天蓝墨 3.M色油墨:泗联洋红墨 4.Y色油墨:泗联中黄墨 5.K色油墨:泗联黑墨	第二: 特别注意: 1.印刷时看样颜色请参考我司提供的实物样品颜色,不得偏色。 2.322C的专色不得参考C=100, M=28.42, Y=48.29, K=21.6 对应的四色色谱颜色来看样印刷
	 Pantone322C  C=0, M=95, Y=100, K=0  C=83, M=52, Y=0, K=0  Black (五色印刷)
折叠方式: 骑马钉	备注:

特别注意: 此页内容不印刷

TOTAL



One-Stop Tools Station

TOTAL

MIST DUSTER

TP541141



 TOTAL TOOLS WORLD
 TOTAL TOOLS WORLD



14L

Warning to users

* * The engine must use mixed fuel. The ratio between gasoline and oil is determined by the oil for gasoline is No.70 or No.90 and the oil should be two-stroke oil for gasoline engines (It is strictly prohibited to use the other kinds of oil).

* * The engine should run without load for 3—5 minutes after start and before stop. It is strictly prohibited that the engine runs at high speed without load in order to avoid the damage of the engine parts and the harm of body. It is also strictly prohibited to stop the engine suddenly at high speed.

* * To prevent fire, the engine must stop and be far away from fire sources when adding fuel .Smoking is strictly prohibited!

Main Features

1. The main parts of the machine are all made of plastic, so the machine has light weight.
2. The construction design of the machine is unique. The parts contacted with chemical are all made of reinforced plastic or stainless steel, thus it has the property of anti-corrosion and long life in use.
3. The dimensions of the mouth on the chemical tank is big, thus to fill the chemical is easy and chemical in bags can be directly poured into the hole.
4. The dimension of lower part of the frame is bigger and the center of gravity of the machine is low, so the stability of the machine is good.
5. Recoil starting engine is adopted, so it is easy for operation. There are protective structures for the high temperature components and it is safe for use.
6. The rotating structure is used in the connection between hose and fan casing, it is easy for operating. The hose has long life in use.

Assembly for Varieties of Operating Condition

1. Assembly for spraying

- 1) Remove the tow wing nuts fixed on the chemical tank and take down the tank. Change dusting lid plate for spraying lid plate, then assemble the chemical tank and screw down wing nuts as shown in Fig.1.

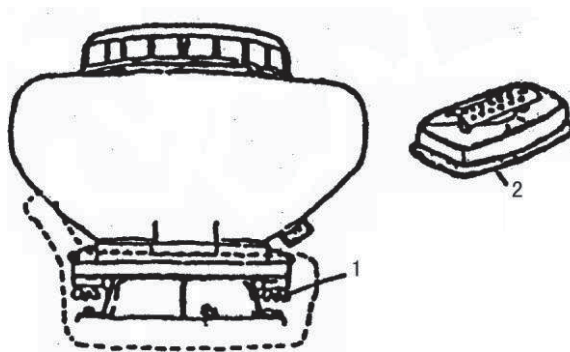

Fig.1
1.Nut
2.Dusting Plate

2) Assembly in chemical tank

Remove the lower cover of chemical tank, change into the pressing lid which is connected with rubber tube (do not forget to put on the sealing ring, as Fig.3). Connect the lid to the rubber tube as shown in Fig.2.

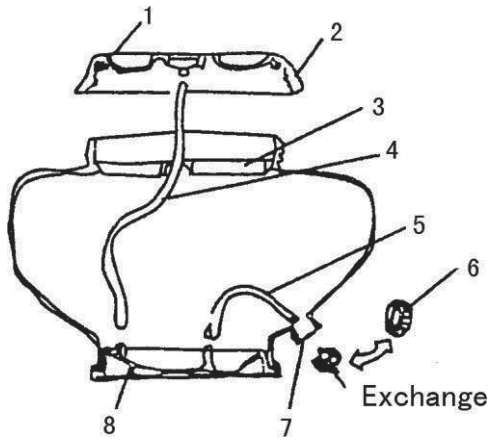

Fig.2

- 1.Sealing washer
- 2.Lid
- 3.Filter net
- 4.Tube
- 5.Rubber tube
- 6.Lower Lid
- 7.Discharge opening
- 8.Spraying plate

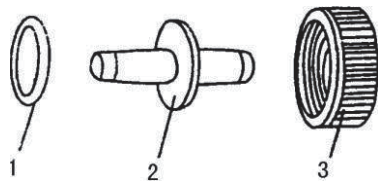

Fig.3

- 1.Sealing washer
- 2.Connector
- 3.Pressing lid

3) Connect spraying pipe to the machine as shown in Fig.4.

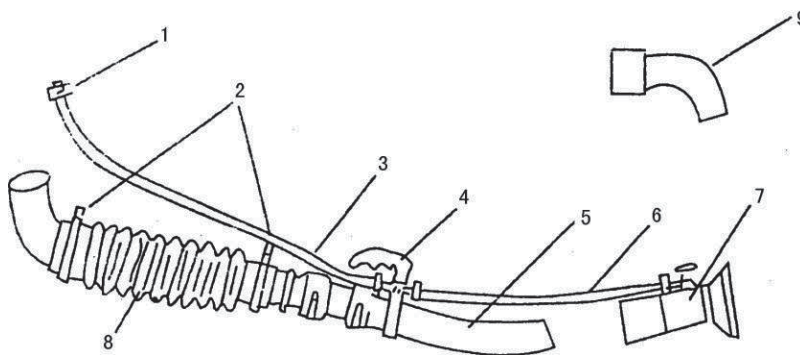

Fig.4

- 1.Clip(A) 2.Clip(B) 3.Plastic tube 4.Handle
- 5.Bentpipe 6.Plastic pipe 7.Nozzle 8.Hose 9.Pipe

2. Assembly for dusting

Remove the chemical tank, take down the inlet rubber tube, outlet rubber tube, strainer, spraying lid plate ,pressing lid and union, change for lower lid of chemical tank, then connect the dusting pipe as Fig.5.and Fig.6.

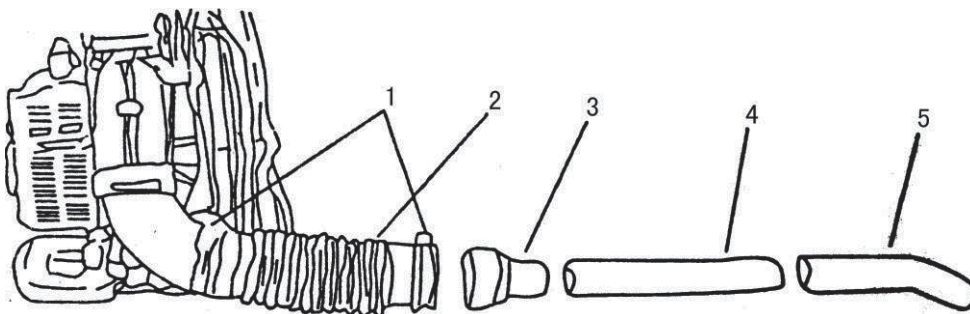

Fig.5

1.Clip 2.Hose 3Union 4.Connecting pipe 5.Dusting pipe

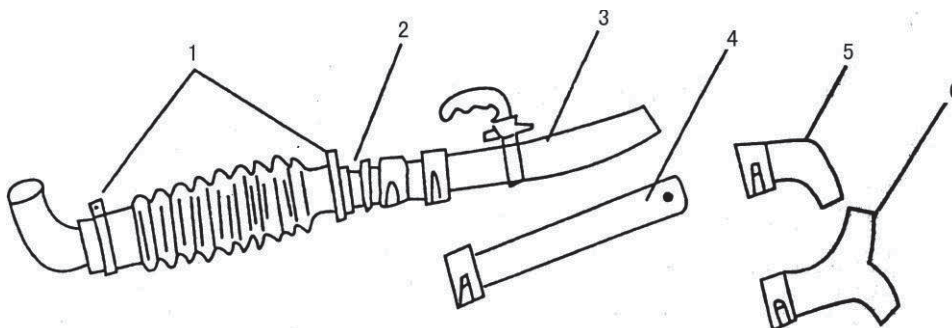

Fig.6

1.Clip(B) 2.Connector 3.Bentpipe 4.Connecting pipe 5.L-Pipe 6.Y-Pipe

3. Anti-electrostatic installation

Dusting or spreading granules chemical may cause the electrostatics that is related to the factors, such as the kind of chemicals, air temperature, air humidity, etc. In order to prevent electrostatics, please use the attachment-insurance chain. When the air becomes dryer, the electrostatic is serious, in particular when the long membranous tube for dusting and granules spreading in used, electrostatic will often happen. Please pay attention.

Assembly as Fig 7.

One end of insurance chain is inserted in jet pipe, vibrated freely and touched to the ground.

Connect another end conducting wire, then fix conducting wire and insurance chain on bend pipe by screw.

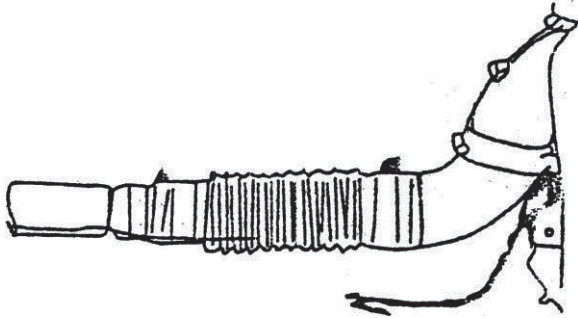

Fig.7

Rotation

1. Check

- 1) Check if there is loose of sparking plug, etc.
- 2) Check if the air cooling opening is blocked to avoid over-heating during rotation.
- 3) Check if air filter is dirty to avoid bad rotation and over-waste of fuel caused by quality of incoming gas.
- 4) Check if the gap of the sparking plug is 0.6-.07mm.
- 5) Pull the starter for 2—3times to see if engine is in normal operation.

2.Adding chemical

- 1) Adding fuel must be done at the state of the engine stop
- 2) The gasoline should be No.70 or No.90; the oil must be two-stroke gasolin engine oil. The mixture's ratio between gasoline and oil is 25-30:1. Bad quality fuel will influence the engine's performance and destroy the gasoline engine. While adding fuel, fuelfilter must not be removed in order to avoid dirty matter coming in fuel tank.

3.Adding chemical

- 1) During spraying operation, while adding chemical, the switch must be shut, see Fig.8. During dusting operation, dusting value throttle and fuel lever should be on the bottom position, otherwise, the machine will have chemical out.

2) As powder chemical can easily become block, so the chemicals should not be in the chemical tank for a long time.

3) While spraying, the chemical tank lid should be turned on tightly. After adding powder chemical, please clean the screw of chemical tank mouth, and then turn on the lid tightly.

4.Cold starting

Please operate according to the following procedures:

- 1) Turn on the fuel switch, see Fig.9.
- 2) Put the fuel lever on the starting position.
- 3) Put the choker on the full position.
- 4) Pull the starter for a few times and have it returned slowly. Do not leave the handle to return freely to avoid the damage of the starter.
- 5) Close the choker and pull starter handle until the engine fires.
- 6) After starting the engine, open choker fully.
- 7) Let the engine run at low speed for 2—3 minutes, then start the spraying or dusting operation.

5.Starting the warm engine

- 1) Leave the choker fully open.
- 2) If the engine draws in too much fuel, leave the fuel switch fully close, pull the starter 5—6 times. Then start the engine as above.

6.Speed adjustment

Speed dose not meet the fixed number with the fuel lever at the working position or the engine can not stop with the handle at the lowest position. Regulate as the following. See Fig. 10.

- 1) Loosen the lock nut.
- 2) Turn the regulating screw right to decrease the

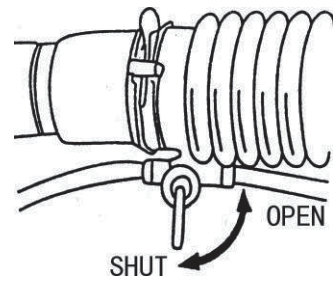

Fig.8

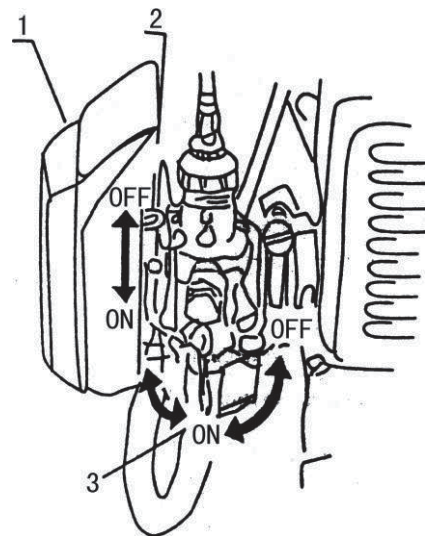

Fig.9

1. Air filter 2.Choke handle 3.Fuel switch

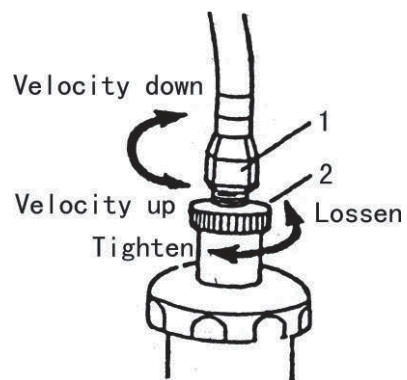

Fig.10

speed. Otherwise, the speed.

3) After adjustment is finished, tighten the lock nut.

7. Stopping the engine.

- 1) During misting operation turn off the chemical first, and then stop the machine.
- 2) During dusting operation, put the fuel lever and dusting lever at the close position.
- 3) After finish work, turn off the fuel switch in order to avoid difficult start next time.

Note: While the engine is running, the hose must be mounted to the machine, otherwise, cooling air will be reduced and the engine may be damaged.

Misting/Dusting

1) Misting. Loosen the pressing lid, regulate the length of the nozzle opening to meet the different requirement of misting. Turn the regulating valve to change the amount of misting. See Fig 11.

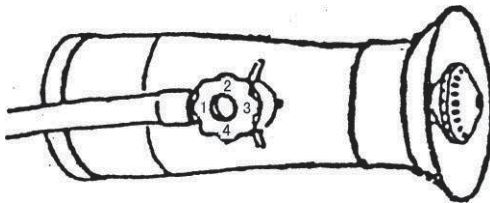

Fig.11

Opening	Discharging(L/min)
1	1
2	1.5
3	2
4	3

2) Dusting. Regulate the discharge rate by shifting the dust rod's position in the three holes of the rock-arm. See Fig12

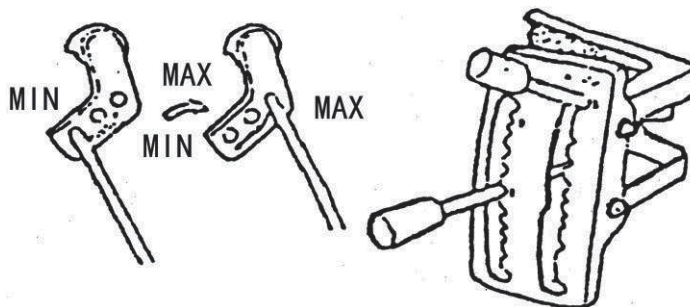

Fig.12

Safety

1. Read this manual carefully. Be sure you understand how to operate this machine properly before you use it.

2. Protective clothing (Fig 13)

- (1) Wear flanged cap.
- (2) Wear dirt/fog-proof glasses.
- (3) Wear gauze mask.
- (4) Wear long gloves.
- (5) Wear coat guarding against poisons.
- (6) Wear boots.



Fig.13

3. Following personnel can not use the machine.

- (1) Mental patients.
- (2) Drunk.
- (3) Under age or old person.
- (4) Person with no knowledge of the machine.
- (5) Dog-tired person or patient and others who can not operate the machine normally.
- (6) Person who have just exercised strenuously or slept not enough.
- (7) Women giving the breast to baby or being pregnant.

4. Avert fire

- (1) Do not fire or smoke nearby the machine.
- (2) Never refuel the machine when it is hot or running.
- (3) Never pour fuel on the machine. If you do, clean them off.
- (4) Always tighten the fuel tank lid.
- (5) Always move at least 10 feet away from the fuel container before starting the machine.

5. Starting engine (Fig 14)

- (1) Put the dust gate handle to the lowest position before starting the engine, otherwise chemical will be jettted when starting engine.
- (2) It is prohibited to stand in front of nozzle. Even

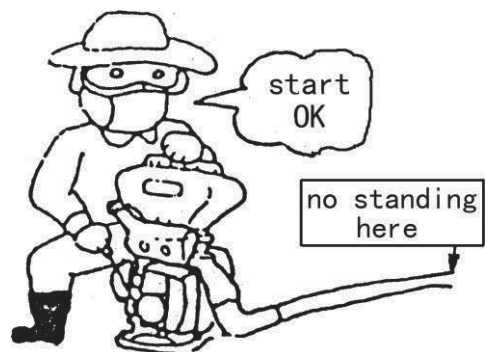

Fig.14

though dust gate is closed, residual dust in pipe will be blown out. Shown in Fig 14.

6. Misting/Dusting

(1) It is fine to carry out operation during cool weather with little wind. For example: in the early morning or in the late afternoon. This can reduce the evaporation and drift of chemicals and improve the protecting effect.

(2) Operation should move windward.

(3) If your mouth or eyes are spattered with chemicals, wash them with clean water and then go to see doctor.

(4) If the operator has a headache or dizziness, stop working at once and go to see the doctor in time.

(5) For the operator's safety, missing/dusting must be carried out strictly according to the instruction of the chemicals and agricultural requirements.

(6) The operator should obey the instructions on the label when preparing the pesticide.

(7) It is prohibited to use the special fluid, such as the strong acids or alkali, etc.

Troubles and Remedies

1. Engine starts difficultly or can not start.

Check if the sparking plug has sparked-over. Screw down the sparking plug; put the side pole to touch the cylinder. Full the starter and watch between the poles of sparking plug whether there are sparks. Pull the starter carefully; do not touch the metal part of sparking plug for prevention of getting an electric shock as shown in Fig.15.

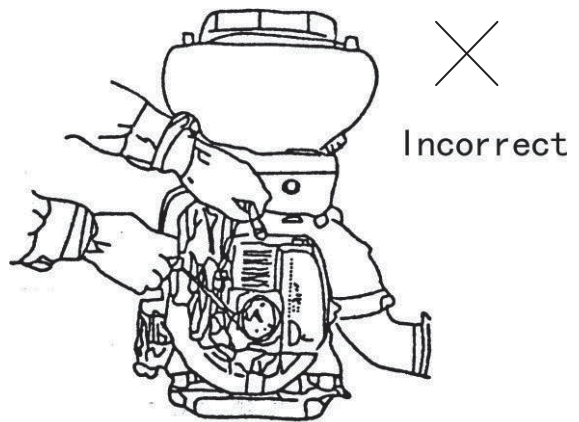

Fig.15

Trouble		Cause	Remedies
No flash	Spark plug	Firing device wetted	Dry it out
		Carbon lay down on the sparking plug	Clean the carbon
		The clearance between poles of sparking plug is too big or too small	Adjusting the clearance at 0.6—0.7mm
		This insulation of sparking plug damaged	Change sparking plug
		Poles burned	Change sparking plug
	Magneto	Wrapping of wire damaged	Change or remedy
		Insulation of coil is broken	Replace
		Wire of coil is broken	Replace
		Electronic firing device damaged	Replace
Normal	Compression ratio is fine & fueling normally	Fuel sucked in is excessive	Reduce the fuel
		Bad quality fuel , mixed with water or dirty	Change the fuel
	Fueling is normal but compressing ratio is bad	Cylinder and piston ring wore and tore	Change cylinder and piston ring
		Spark plug is loosen	Tighten
	No fueling form carburetor	No fuel in fuel tank	Fill fuel
		Filter net dirty	Clean it
		Air hole of fuel tank blocked	Clean it

2. Engine output is insufficient

Trouble	Cause	Remedies
Compression ratio & fire is normal	Filter plate clogged	wash
	Fuel mixed with water	Change fuel
	Engine overheat	Shut down or cool it
	Carbon lay down in muffler	Clean it
Engine overheat	Consistency of fuel is too thin	Adjust carburetor
	Carbon lay down on cylinder cover	Clean it
	Engine oil is bad	Use special mobile oil
	No connection with hose	connect
Dash sound	Bad fuel	Replace
	Carbon lay down in combustion chamber	Clean it
	Running parts wore and tore	Check & change

3. The engine shuts down in running.

Trouble	Cause	Remedies
The engine shut down suddenly	The lead wire of sparking plug loosened	Connect if firm
	The piston bitten	Change the piston or remedy it
	The sparking plug laid down the carbon or short circuited	
	The fuel burned up	Feed the fuel
The engine shut down slowly	Inside the carburetor clogged	Clean it
	The air hole of fuel tank clogged	Clean it
	The fuel mix with water	Replace the fuel

4. The engine shuts down difficultly

Trouble	causes	remedies
The fuel lever handle is located at the lowest position, the engine still runs.	The fuel pulling cord is too short (the idle speed is higher)	Adjust the pull cord according to Fig.13.

5. Spraying

Trouble	causes	remedies
No spray mixture jet or jet intermittently	Nozzle switch or control valve clogged	Clean it
	Liquid lead pipe clogged	Clean it
	No pressure or the pressure is lower	Tighten the tank lid and screw down two wing nuts
Spray mixture leakage	The spraying lid plate fitted incorrect	Refit it
	Every threaded joint loosened	Screw down it

6. Dusting

Trouble	Causes	Remedies
No dust discharge or discharge intermittently	No dust gate can not be opened	Adjust the pull rod of the dust gate
	The dust or granule mix with foreign body	Clean it
	The dust or granule lumped	Break the lump
	Wet dust or granule	Dry it
The dustgate not work properly	The dust gate can not be closed	Adjust the pull rod of the dust gate
	The dust gate is blocked up by foreign matter	Clean it
Leakage of dust	The clamp plate of the chemical tank bottom loosened	Tighten it
	The sealing gasket of the dusting lid damaged	Change it with new one
The discharge rate out of control	The control device of dust gate can not work properly	Remedy it

Technical Maintenance and Deposit for a Long Time

1. Technical maintenance on spraying assembly

(1) After spraying, clean out any residual spray mixture or dust in the chemical tank. Wash the tank and all other parts.

(2) After dusting or granules spreading, clean the dust gate and chemical tank inside and outside.

(3) After operation, loosen the chemical tank lid.

(4) After cleaning, the machine runs at low speed for 2—3 minutes.

2. Maintenance on fuel system

(1) The fuel mix with dust or water is one of main cause of the engine trouble, so the fuel system should be cleaned very often.

(2) If the residual fuel remains in the fuel tank and carburetor for a long time, the residual fuel would be glued and the fuel circuit clogged, thus causing the engine not to working properly. So as the machine works for one week. All of the fuel should be discharged.

3. Maintenance on air filter and sparking plug

(1) After the operation each day, wash the filter, if the chemicals adhere to sponge, it would deduce the engine power, please pay attention especially.

(2) After wash the sponge with petrol, squeeze the petrol then fix the sponge in.

(3) The suitable clearance of sparking plug is 0.6—0.7mm, please check the clearance often, if it is too big or too small, adjust it properly, as shown in Fig.16.

(4) The sparking plug model of this machine is 4106J. Do not use other model. If it is necessary for change, you may buy it form local agricultural machinery department or plant protection department.\

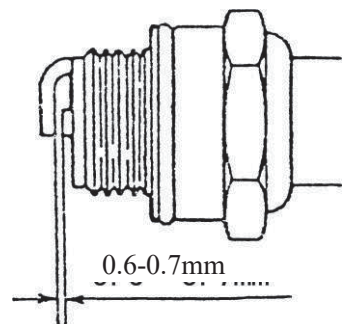

Fig.16

4. Deposit for along time

(1) Clean the outside of the machine. Coat the anti-rust oil to the surface of metal.

(2) Take down the sparking plug. Feed 15—20g mobile oil into cylinder, the mobile oil should be specially used for two-stroke petrol engine. Raise the piston to upper terminal point, then fix

sparkling plug.

(3) Screw out the two wing screws. Take off the machine tank. Clean the dust gate and the surface inside and outside of chemical tank. If the residual chemical remains in the dust gate, the dust gate will not properly and the leakage of dust will occur seriously. Then fit the chemical tank on and the loosen the tank lid.

(4) Take off the spray unit and wash it and then store additionally.

(5) Should discharge all the fuel in the fuel tank and carburetor.

(6) Cover the machine with plastic membrane and deposit it at dry and no dust plac

Technical data

Item No. :	TP541141
Discharging Capacity:	41.5cc
Chemical tank:	14L
Fuel tank:	1.4L
Liquid output:	more than 2.5L/min
Powder output:	more than 3kg/min
Vertical Range:	8 meter
Horizontal range:	12 meter
Power:	2.13/7500 kw/r/min

TP541141 Exploded view

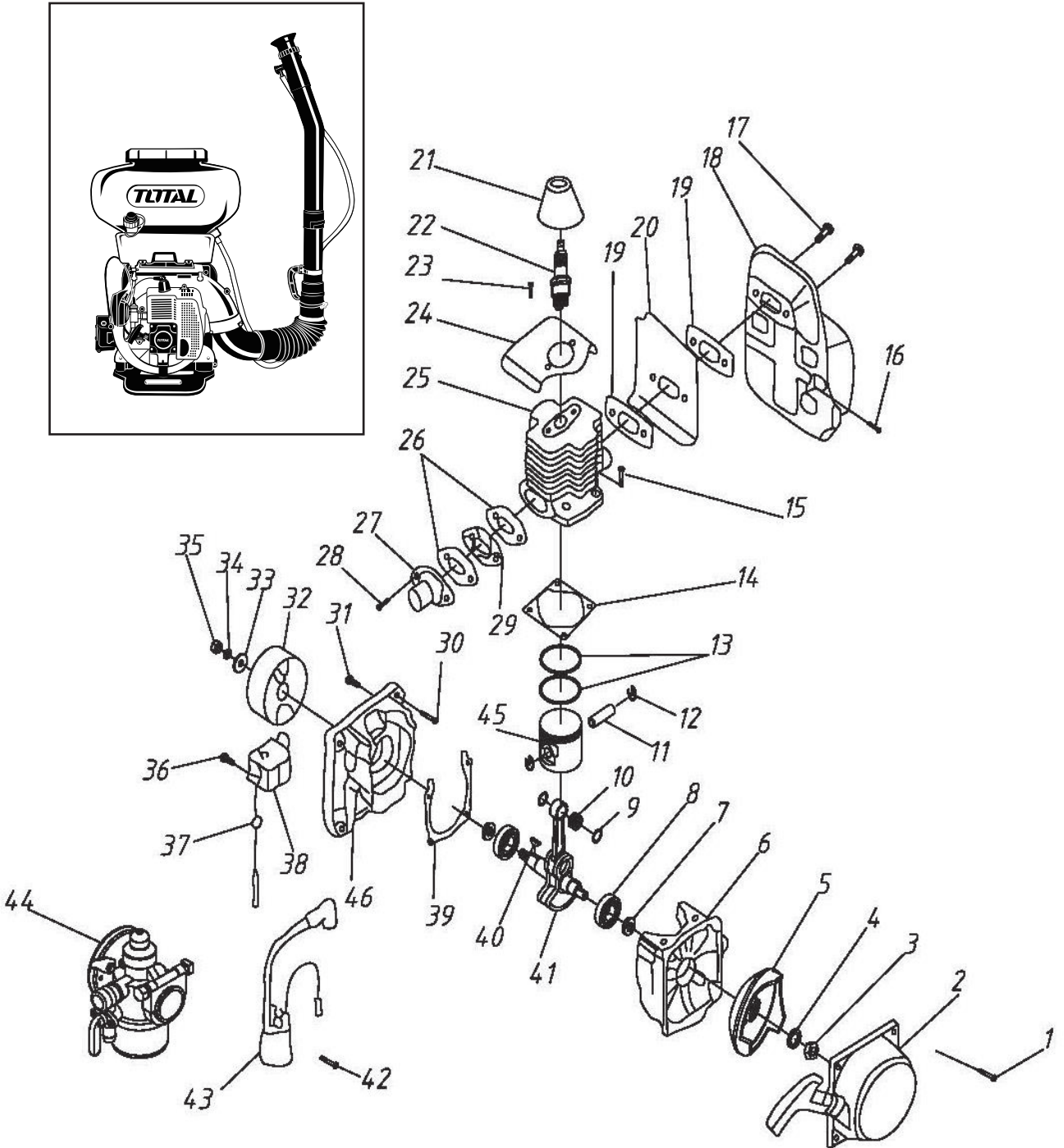

TP541141 Spare part list

NO.	Part Description	Qty
1	Screw assemblies m 5 x16	4
2	Starter	1
3	Nuts	1
4	Gaskets	1
5	Starter dial	1
6	Rear half crankcase	1
7	Oil Seal	2
8	Bearing	1
9	Thrust Washer	2
10	Needle roller bearing with small head	1
11	Piston Pin	1
12	Piston pin retaining ring	1
13	Piston ring	2
14	Cylinder block gasket	1
15	Screw M5x20	4
16	Screw assembly M5x12	1
17	Screw M6x35	1
18	silencer	1
19	Muffler pad	1
20	Silencer windshield	1
21	Spark plug housing	1
22	Spark plug	1
23	Screw assembly M5x10	1

NO.	Part Description	Qty
24	Wind shield	1
25	Cylinder	1
26	Intake pipe gasket	1
27	Intake pipe	1
28	Screw assembly M5X25	1
29	Insulation pads	1
30	bolt M6x32	1
31	Screw M5x30	1
32	Magneto rotor	1
33	washer 859-10	1
34	washer 97.1-10	1
35	Nut M10	1
36	Screw M4x25	2
37	Ignition wire fixing sleeve	1
38	Stator coil	1
39	Crankcase gasket	1
40	Half round key	1
41	Crankshaft connecting rod group	1
42	Screw 4.2X16	2
43	Ignition coils	1
44	Carburetor	1
45	piston	1
46	Front half crankcase	1

TP541141 Exploded view

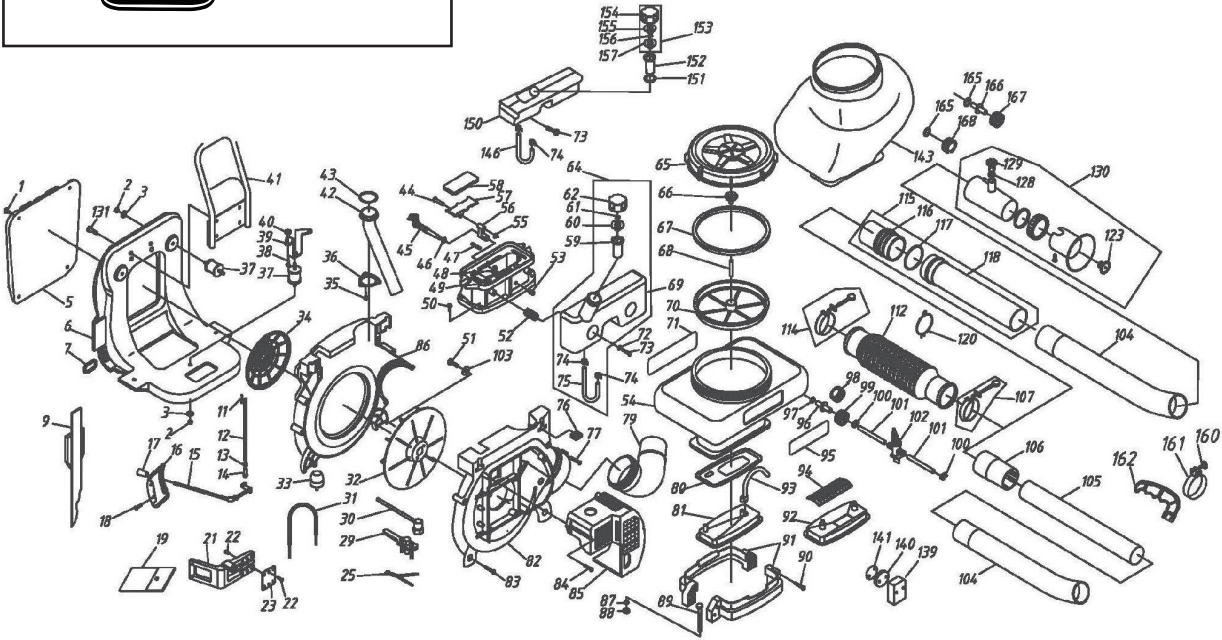
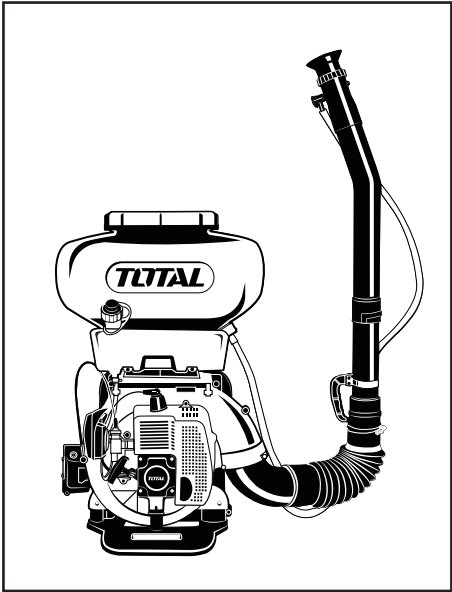

TP541141 spare part list

No	Part Description	QTY
1	Back pad clip	5
2	Nut	6
3	washer	7
5	Back cushion parts	1
6	frame	1
9	strap	1
11	Split pin	1
12	Pink door lever	1
13	Nut	1
14	Connector body	1
15	Powder door control lever welding	1
16	Adjustable shell	1
17	Handle	2
18	Screw assembly	4
20	Throttle lever welding	1
22	Screw assembly	4
23	Pad	1
30	Socket wrench	1
31	Throttle rope parts	1
32	impeller	1
33	Support column parts	2
34	Fan net cover	1
35	Screw	3
36	cover	1
37	Damping column combination	3
38	Screw assembly	2
39	Bottom support combination	1
40	Connection pad	2
42	Powder tube	1
43	Sealing ring	1
44	Skateboard pin	1
45	Rocker shaft	1
47	pin	1
48	Retaining ring	1
49	Valve body	1
50	Bolt assembly	4
51	bolt	2
52	Fuel tank support column	2
53	Plug	1
54	medicine chest	1
55	Retaining ring	1
56	Support arm	1
57	skateboard	1
59	Oil net casting	1
60	Fuel tank inner cover	1
61	Filter element	1
62	Fuel tank cap	1

No	Part Description	QTY
69	tank	1
70	Medicine Net Casting	1
74	Tubing clip	2
76	Square nut	4
77	Long screw	2
80	Spray cover sealing ring	1
81	Spray cover	1
82	Front half volute assembly	1
79	Fan elbow	1
86	Rear half volute combination	1
83	Screw	9
84	Screw	4
85	protecting mask	1
87	washer	2
88	Nut	2
89	bolt	2
90	Screw assembly	2
92	Powder spraying cover	1
93	Infusion short tube	1
94	Under the powder partition	1
96	take over	1
97	Medicine box lower cover sealing ring	1
98	Lower cover of medicine box	1
99	Take over the gland	1
100	Water pipe clamp	4
101	tube	0.9M
102	Switch combination	1
104	Long elbow	1
105	Connecting pipe	1
106	Air duct	1
115	Joint combination	1
116	Connector	1
117	O-ring	1
118	Straight	1
107	No. 2 snap ring assembly	1
112	Big hose	1
114	No. 1 snap ring assembly	1
123	Spiral nozzle assembly	1
130	Telescopic black spout	1
131	Screw assembly	4
153	Fuel tank cap assembly	1
154	Fuel tank cap combination	1
155	Plastic inner cover	1
156	Filter element	1
157	Rubber inner cover	1
161	Handle	1
162	Handle snap ring	1

TOTAL

One-Stop Tools Station

TOTAL

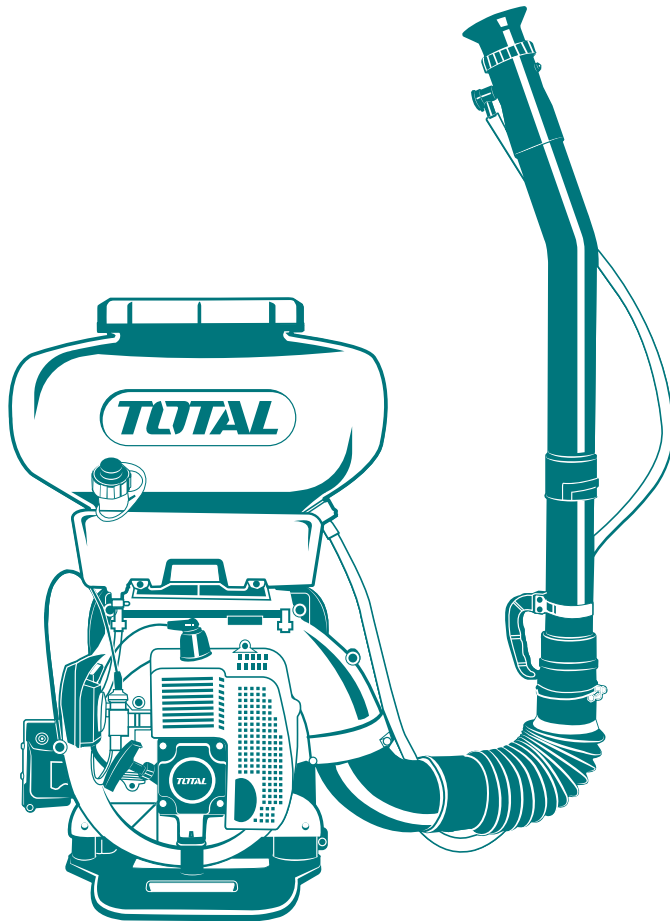

MIST DUSTER

www.totalbusiness.com

TOTAL TOOLS CO., PTE. LTD.

No.45 Songbei Road, Suzhou Industrial Park, China.

MADE IN CHINA

T1020.V01

14L